

**PRODUCT FEATURES**

- Short stack on grille allows for continuous installations in 5/8" thick gypsum board without cutting wall studs.
- Non-removable core
- 7 core styles available
- Maximum single piece length to 116"
- Duct heights from 2" up to 18"
- Full sections only
- Countersunk screw holes in border with steel screws (Mounting Type C) is standard for assemblies with borders. Optional concealed mounting available for cores with 1/2" blade spacing.

**CONSTRUCTION DETAILS**

**Material:** All Aluminum Construction

**Finish:**

- Arctic White
- Other Colors Available (opt)

**CORE CONSTRUCTION**

- See Core Options submittal sheet
- Core Blades: Parallel to length dimension

**Mounting Method**

- Mounting "C"** - Screws Holes in Face
- Mounting "D"** - Concealed Mounting (1/2" blade spacing ONLY. Brackets & #8x1-1/2" screws shipped loose for field installation.)

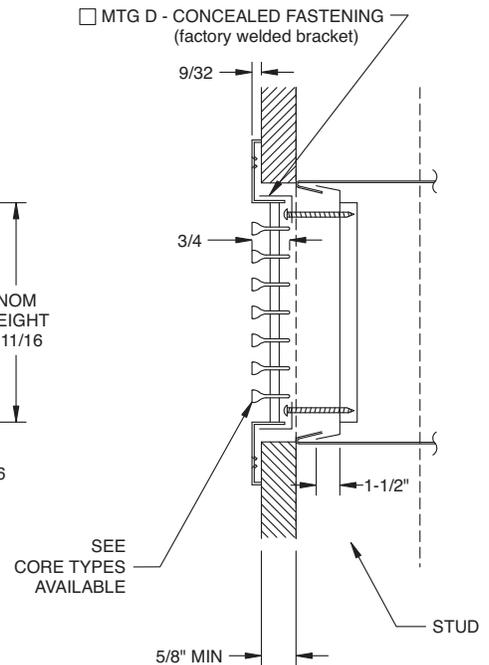
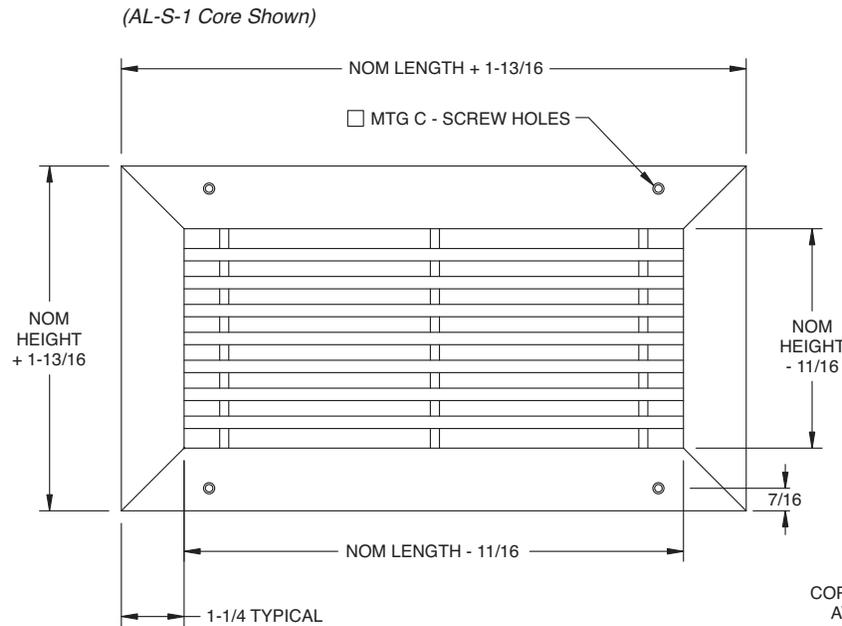

All dimensions are in inches.

**JOB NAME:**

**SUBMITTED BY:**