



# Anemostat® SUBMITTAL

1220 Watson Center Road • Carson, CA 90745-4206  
(310) 835-7500 • FAX (310) 835-0448  
air@anemostat.com • www.anemostat.com

Model **AIRLINE**  
**ALUMINUM LINEAR BAR GRILLE**  
STACK MITER  
OUTSIDE CORNER (90°)  
FOR FG & FH BORDER

## GRILLES & REGISTERS

### PRODUCT FEATURES

- Heavy gauge, extruded aluminum construction
- Available in any frame / core combination

### CONSTRUCTION DETAILS

**Material:** All Aluminum Construction

**Finish:**

- Arctic White
- Mill Finish
- Natural Anodize
- Anemostat Color # \_\_\_\_\_
- Custom Color Match \_\_\_\_\_

### Models

- AL1** - 1/4" Bars on 1/2" Ctrs. - 0°
- AL15** - 1/4" Bars on 1/2" Ctrs. - 15°
- AL45** - 3/16" Bars on 1/2" Ctrs. - 45° (FG border only)
- TL1N** - 1/8" Bars on 1/4" Ctrs. - 0°
- TL1W** - 1/8" Bars on 1/2" Ctrs. - 0°
- TL15N** - 1/8" Bars on 1/4" Ctrs. - 15°
- TL15W** - 1/8" Bars on 1/2" Ctrs. - 15°

- NOTES:** - AL1 with FH border shown  
 - 90° shown; other angles available  
 - See Airline borders & frames submittal sheet for detailed dimensions  
 - Arrows indicate air flow direction on plan view sectional drawing

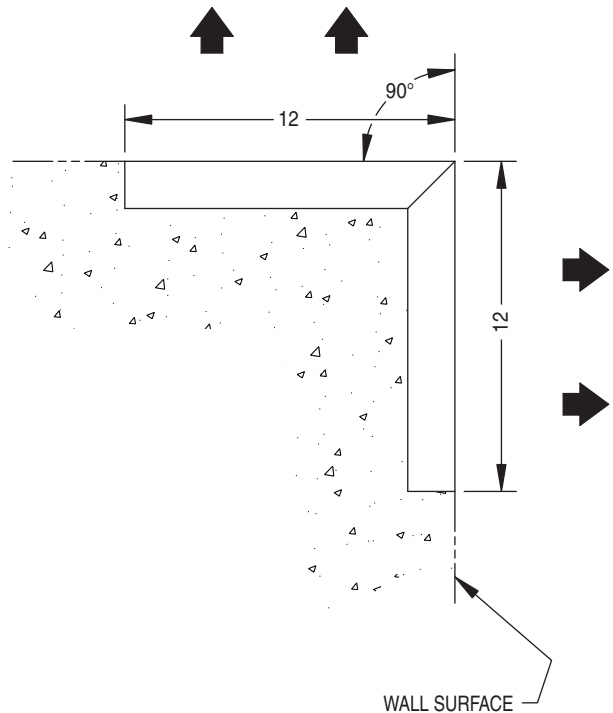
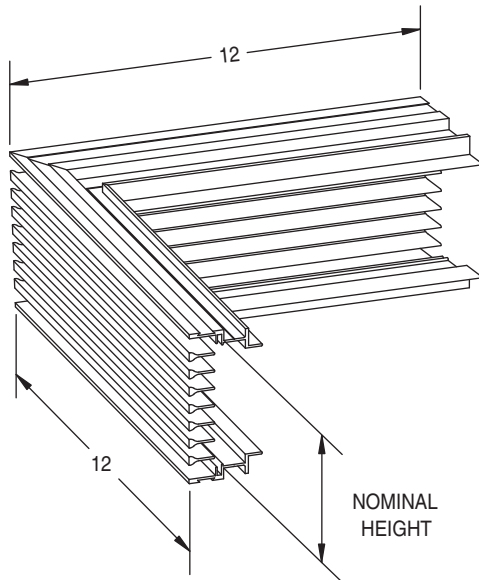

All dimensions are in inches.

JOB NAME:

SUBMITTED BY: