

PRODUCT FEATURES

- Extruded aluminum construction
- Lengths to 120" for full sections. Unlimited length continuous runs (96" max sections) using frame alignment strips.
- Minimum Nominal Height = 1-1/2" (2" with rear louvers)
- Alignment hardware shipped loose
- Core construction (AL1 Shown) see Core Options page
- Removable Core: Standard on heights up to 18"
- Non-Removable Core: Welded in construction on heights over 18"

CONSTRUCTION DETAILS

Material: Extruded Aluminum

Finish:

- Arctic White Baked Finish
- Natural Anodize
- Custom Color _____

CORE CONSTRUCTION

- See Core Options submittal sheet
- Core Blades: Parallel to length dimension

ACCESSORIES

- OB1-ST** Opposed Blade Damper (Steel)
- OB1-AL** Opposed Blade Damper (Alum)

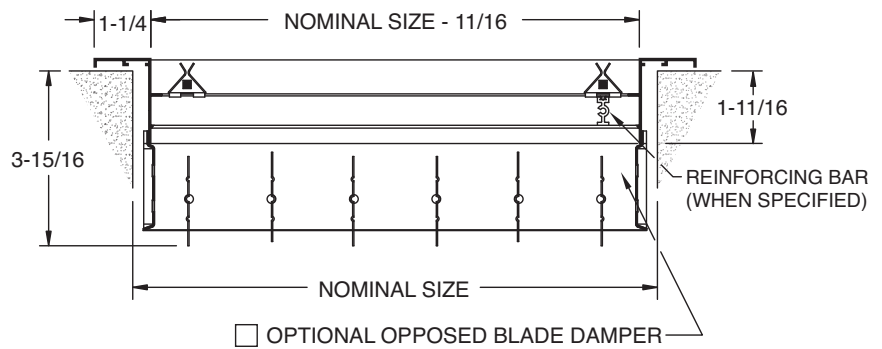
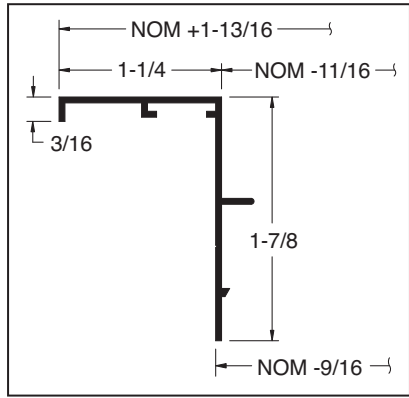
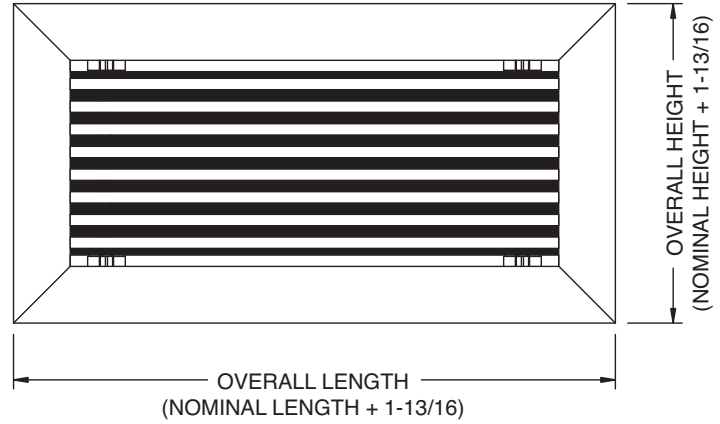
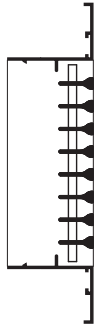

- Nominal Size = Order Size
- Nominal Size = Overall Size - 1-13/16

All dimensions are in inches.

JOB NAME: _____ **SUBMITTED BY:** _____

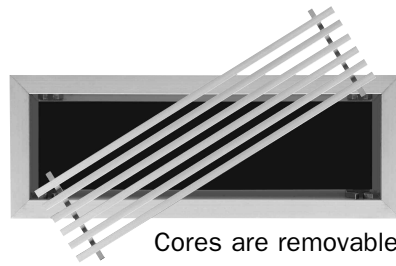

Cores are removable

PRODUCT FEATURES

- Extruded aluminum construction
- (7) Cores to choose from for appearance and deflection angle
- Removable core is standard on heights to 18"
- Non-removable core on heights over 18" (welded)
- Double deflection option includes rear louvers (individually adjustable) for spread control

AL1*
SINGLE DEFLECTION

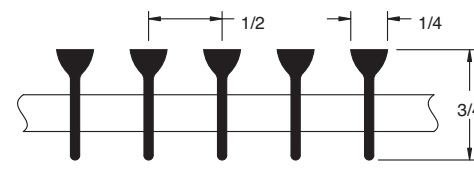

AL2*
DOUBLE DEFLECTION (Spread Control)

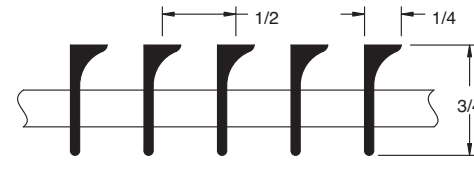

DEFLECTING BAR 0° STANDARD

AL15*
SINGLE DEFLECTION

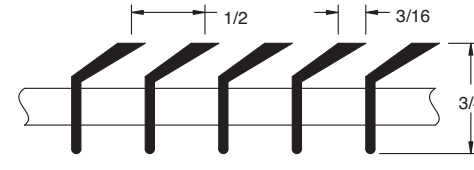

AL25*
DOUBLE DEFLECTION



DEFLECTING BAR 15° STANDARD

AL45*
SINGLE DEFLECTION

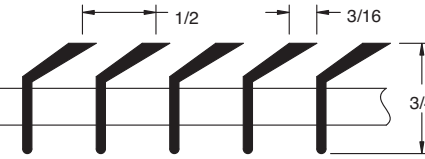

AL245*
DOUBLE DEFLECTION



DEFLECTING BAR 45° STANDARD



PENCIL PROOF

TL1W
SINGLE DEFLECTION

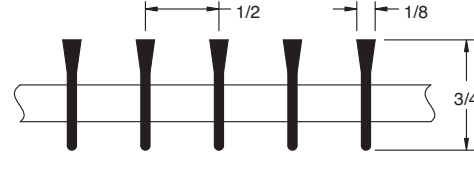

TL2W
DOUBLE DEFLECTION

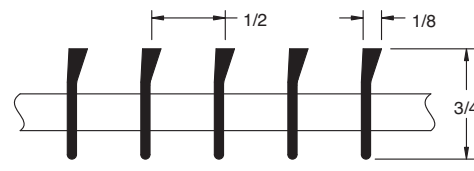

DEFLECTING BAR 0° THINLINE

TL15W
SINGLE DEFLECTION

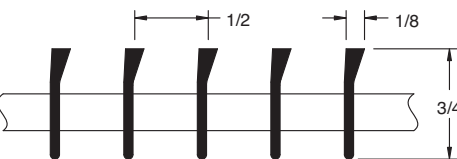

TL25W
DOUBLE DEFLECTION

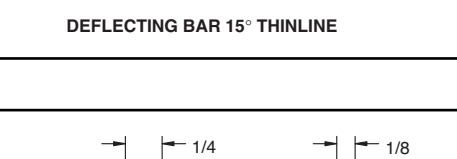

DEFLECTING BAR 15° THINLINE

TL1N*
SINGLE DEFLECTION

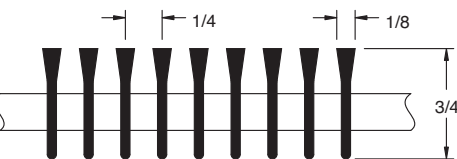

TL2N*
DOUBLE DEFLECTION



DEFLECTING BAR 0° THINLINE

TL15N*
SINGLE DEFLECTION

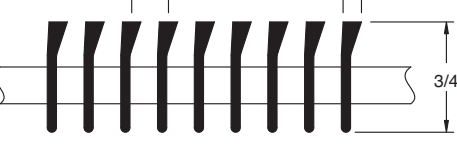

TL25N*
DOUBLE DEFLECTION



DEFLECTING BAR 15° THINLINE



PENCIL PROOF

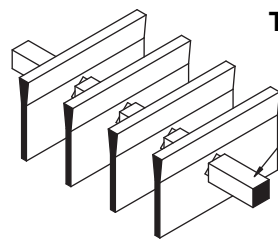

TYPICAL CORE ASSEMBLY

Core cross bars are on 10" centers for AL style cores, 5" centers for TL style cores. Cross bars are 5" centers for all cores used with floor reinforcement.

*PENCIL PROOF: Models AL1, AL2, AL15, AL25, AL45, AL245, TL1N, TL2N, TL15N, TL25N are pencil proof

All dimensions are in inches.

JOB NAME:

SUBMITTED BY: