



Anemostat®

AIR DISTRIBUTION

SUBMITTAL SHEET

www.anemostat-hvac.com



SOUND ATTENUATOR

RECTANGULAR
STANDARD MODEL
MOLD RESISTANT
COTTON FILL

PRODUCT FEATURES

- **FILL:** Mold resistant cotton under compression
- Tested in accordance with ASTM E-477
- Single piece construction from: 6" x 6" to 48" x 48"
- **ASTM-E84 Rating Characteristics:**
Flamespread - 5
Smoke Developed - 35

CONSTRUCTION FEATURES

- **Casing:**
22 Gauge Galvanized Steel
- **Baffles:**
24 Gauge Perforated Galvanized Steel

MODELS

- ARUHP** Ultra High Pressure
- ARHP** High Pressure
- ARMHP** Medium High Pressure
- ARMP** Medium Pressure
- ARMLP** Medium Low Pressure
- ARLP** Low Pressure
- ARULP** Ultra Low Pressure

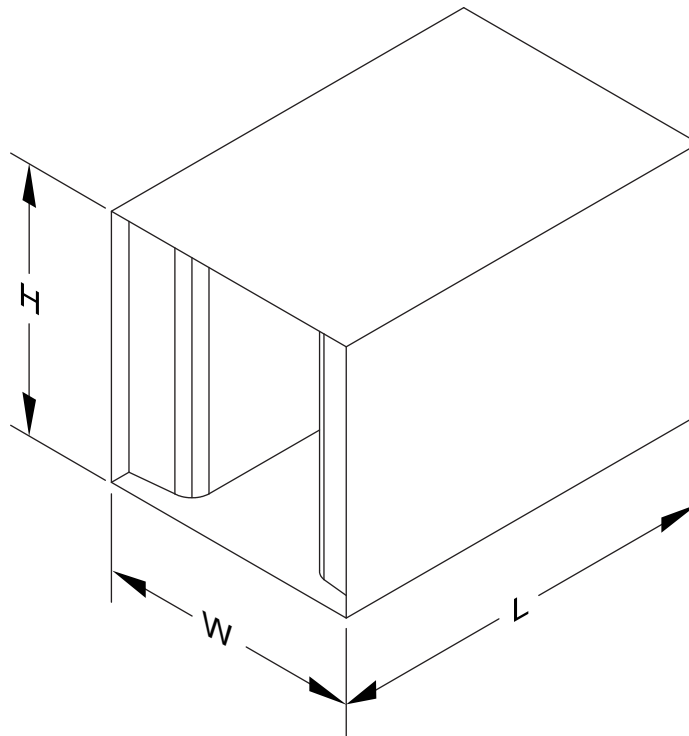

By *AEROSONICS*

All dimensions are in inches.

JOB NAME:

SUBMITTED BY: