



Anemostat®

AIR DISTRIBUTION

SUBMITTAL SHEET

www.anemostat-hvac.com



SOUND ATTENUATOR

RECTANGULAR
HOSPITAL / CLEAN ROOM
MOLD RESISTANT
COTTON FILL

PRODUCT FEATURES

- **FILL:** Mold resistant cotton, encapsulated in polyethylene to eliminate erosion and absorption of gases. An acoustical stand-off is placed between the perforated baffle and the fill.
- Tested in accordance with ASTM E-477
- Single piece construction from:
6" x 6" to 48" x 48"
- **ASTM-E84 Rating Characteristics:**
Flamespread - 0
Smoke Developed - 35

CONSTRUCTION FEATURES

- **Casing:**
22 Gauge Galvanized Steel
- **Baffles:**
24 Gauge Perforated Galvanized Steel

MODELS

- ARUSPC** Ultra High Pressure
- ARSPC** High Pressure
- ARMSPC** Medium High Pressure
- ARMPC** Medium Pressure
- ARMLPC** Medium Low Pressure
- ARLPC** Low Pressure
- ARULPC** Ultra Low Pressure

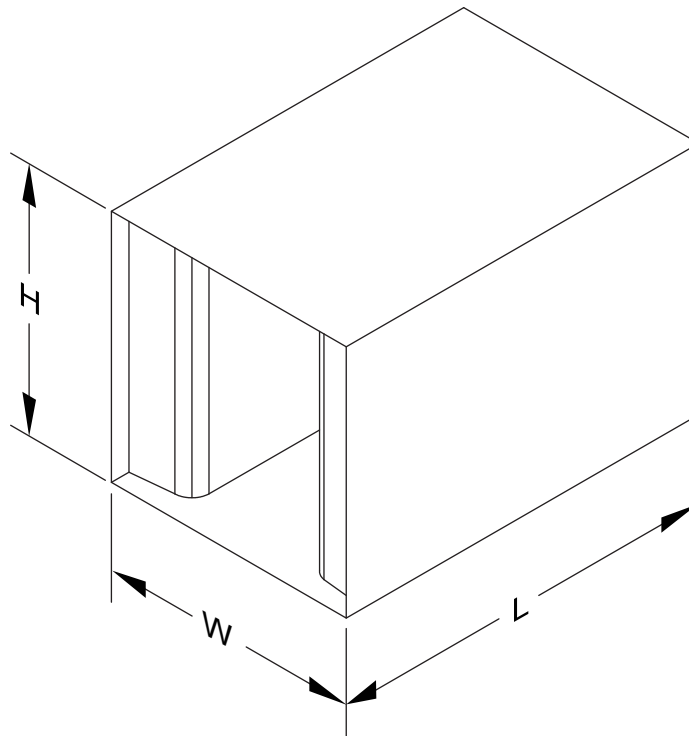

By *AEROSONICS*

All dimensions are in inches.

JOB NAME:

SUBMITTED BY: