

SUBMITTAL SHEET

PRODUCT FEATURES

- Individually adjustable deflector blades allow additional control when needed
- Coated steel construction
- Field installed accessory

CONSTRUCTION FEATURES

- Material:** Steel
Finish: Mill Finish

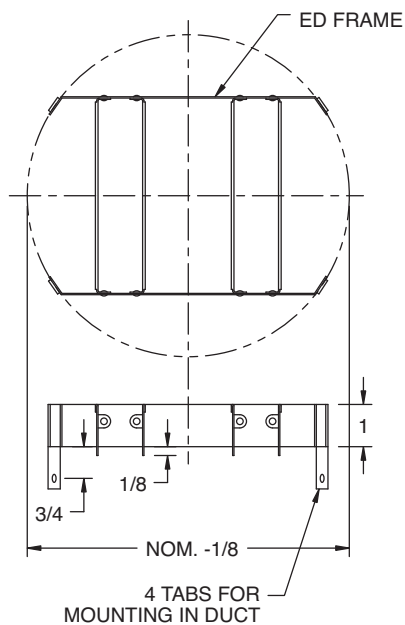

SIZES 4-8

SIZE BY NECK DIA. (I.D.)	E.D. DIA. (OUTSIDE)
4	3-5/8
5	4-5/8
6	5-5/8
7	6-5/8
8	7-5/8

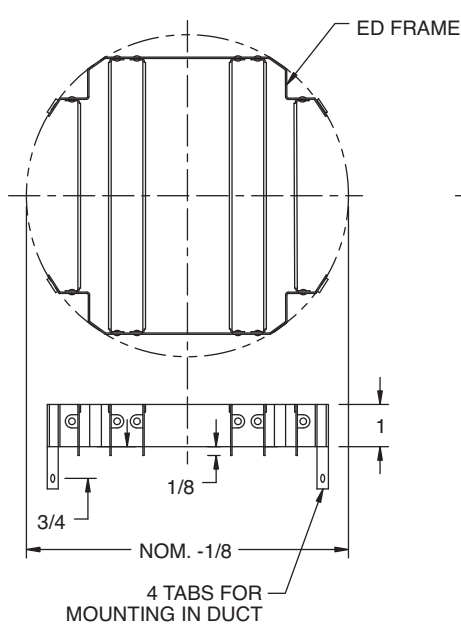

SIZES 9-18

SIZE BY NECK DIA. (I.D.)	E.D. DIA. (OUTSIDE)
9	8-5/8
10	9-5/8
12	11-5/8
14	13-5/8
15	14-1/2
16	15-1/2
18	17-1/2

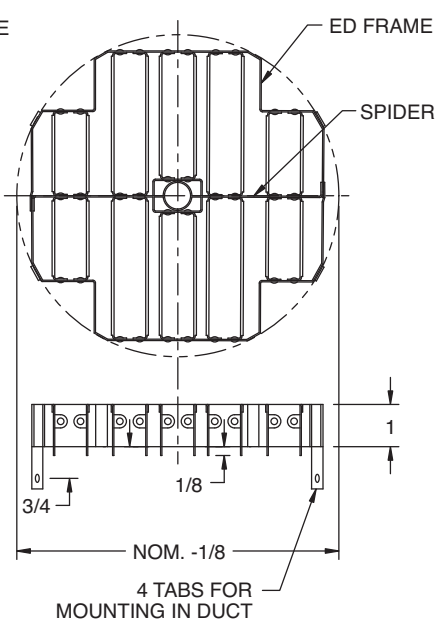

SIZES 21-24

SIZE BY NECK DIA. (I.D.)	E.D. DIA. (OUTSIDE)
21	20-1/2
24	23-1/2

All dimensions are in inches.

JOB NAME:

SUBMITTED BY: