

Installation Guide

Mounting

The CSP-5001/5002 is designed to mount on a standard 1/2 in. (13 mm) diameter shaft or a 3/8 in. (9.5 mm) shaft using the optional HFO-0011 adaptor.

Standard Instructions

1. Slide the CSP-500x directly onto the 1/2 in. diameter damper shaft. The shaft must extend a minimum of 1-3/4 in. from the mounting surface. (For a 3/8 in. shaft, see [HFO-0011 Adaptor on page 1.](#))
2. Place the non-rotation bracket (supplied) on the non-rotation tab. Leave a gap of 1/8" between the bottom surface of the CSP-500x and the bracket to allow for play during operation (see illustration).
3. Attach the non-rotation bracket to the mounting surface using (2) #8 or #10 self-tapping screws (not included).
4. Depress the gear disengagement button and:
 - A. Rotate the drive hub until the indicator stops at the "90" mark if the damper is clockwise to close.
 - B. Rotate the drive hub to the "0" mark if the damper is counterclockwise to close.
5. Position the damper to full open.
6. Torque the two 5/16-18 set screws 75 to 85 in-lb.
7. Depress the gear disengagement button and rotate the drive hub/damper to the closed position.
8. Loosen the adjustable end stop, position against the damper position indicator, and retighten.

HFO-0011 Adaptor

1. Mount the CSP-500x over the 3/8 in. shaft.
2. Slide the HFO-0011 over the shaft into the drive hub of the actuator.
3. Align the adaptor slots with the set screws.
4. Partially tighten the set screws.
5. Continue with Step 2 under the Standard Instructions section above.

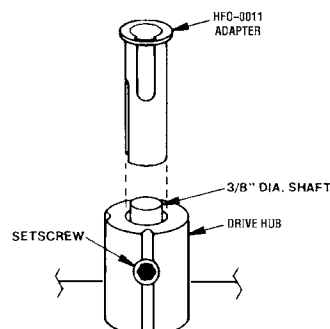
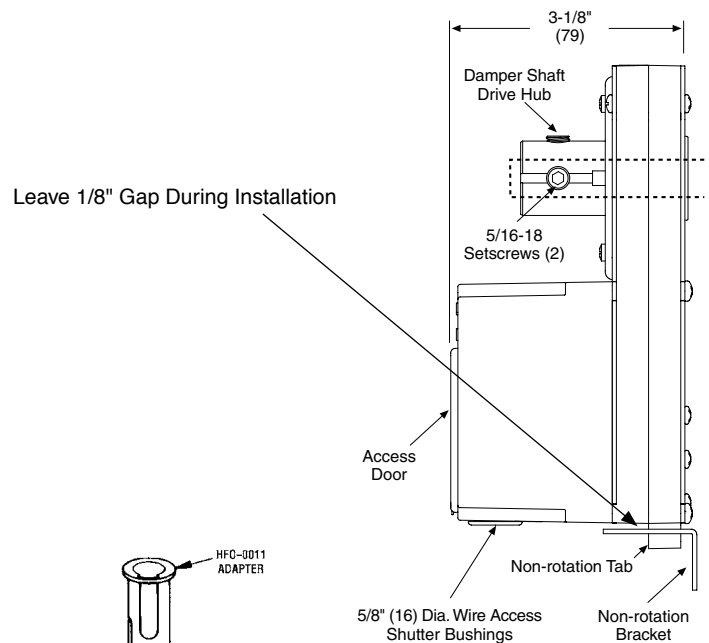
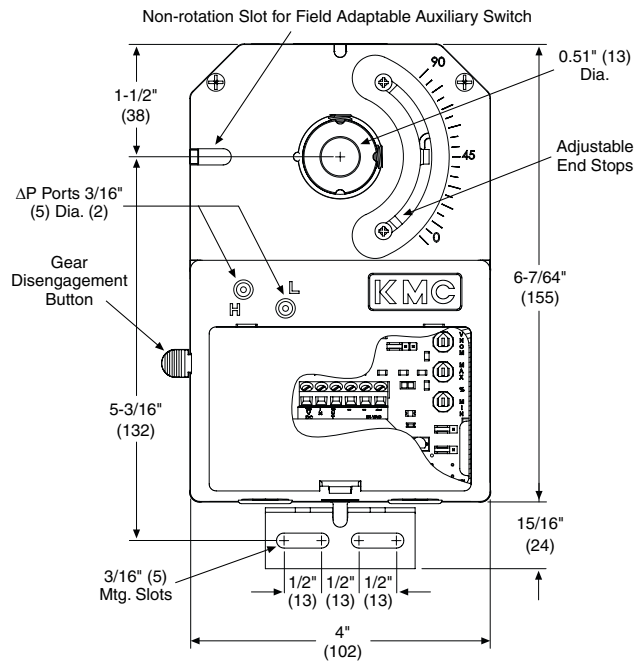

Wiring

1. Remove the CSP-500x's wiring access door by pulling back on the door's tab and lifting upward.
2. Access for wire or cable is via two 5/8 in. (16 mm) diameter snap-in shutter bushings located on the bottom of the cover.
3. Remove the snap-in shutter bushing and replace with one the following connectors as needed (connectors are not supplied — order separately):
 - A. HMO-4518 for 1/2 in. flexible conduit.
 - B. HMO-4520 compression connector for plenum rated cable.
 - C. HMO-4526 female connector 1/2 in. conduit.
4. Connect the CSP-500x to a CTE-5100 series or a CTE-5202 thermostat:
 - A. Terminal "16 VDC" to thermostat terminal "+" (CTE-5100 series) or "~" (CTE-5202).
 - B. Terminal "IN" to thermostat terminal "T1/AO1" for cooling ("T2/AO2" for heating) air flow.

NOTE: If minimum and maximum velocity limits will be set at the CSP-500x (see [Minimum and Maximum Flow Limits on page 4](#)), then use "T3" for cooling and "T4" for heating on a CTE-5100 series thermostat.

- C. Terminal "OUT" to thermostat terminal "V1" for velocity readout at the thermostat.
 - D. Terminal "-" to thermostat terminal "-/∟" (Common).
5. Connect the CSP-500x to a 24 VAC, -15/+20%, 50/60 Hz, 4 VA, Class 2 only power source:
 - A. Terminal "~" to the phase side of the transformer.
 - B. Terminal "-" to the neutral or ground side of the transformer.

6. Reinsert the wiring access door.

NOTE: For more detailed information about connections and usage with CTE-5100 series thermostats, see the [CSP-5001/5002 Application Guide](#).

NOTE: For more detailed information about connections and usage with newer CTE-5202 thermostats, see the [CTE-5202 Applications Guide](#).

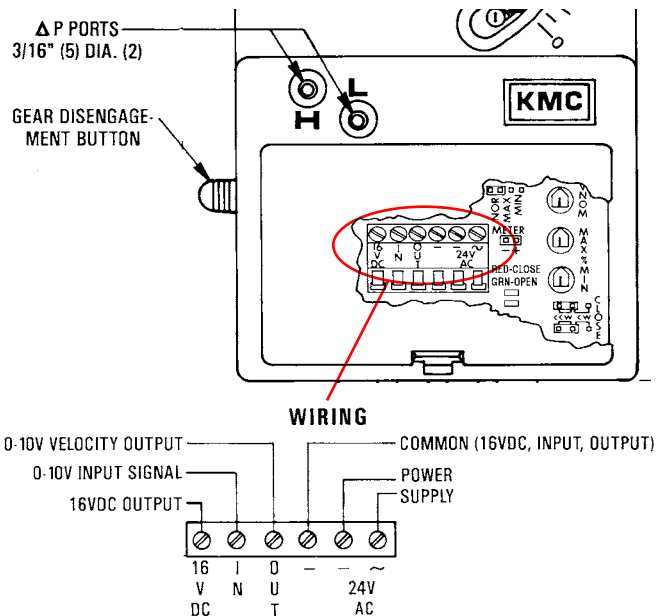

Air Flow Sensor Connection

The CSP-500x is factory calibrated to function with an SSS-1000 series differential pressure flow sensor. Using 24" of 1/4" OD x 0.040" wall "FR" instrument and control tubing, a 3/8" to 1/4" barb union adapter, and 1" of 3/8" OD x 0.062 "FR" tubing for both connections:

1. Connect the "H" port to the (high side) "H" of the sensor.
2. Connect the "L" port to the (low side) "L" of the sensor.

NOTE: To maintain a close correlation with the factory calibration (for 0 to 3300 fpm), the 3/8" OD tubing between the sensor and the adapter should be as short as possible, and the 1/4" OD tubing from the adapter to the controller should be exactly 24" long (on both the High and the Low sides) without other restrictions such as fittings or kinks.

NOTE: The SSS-1000 series differential pressure flow sensor must be mounted with the arrow pointing in the direction of the air flow.

Maintenance

No routine maintenance is required. Each component is designed for dependable, long-term reliability, and performance. Careful installation will also ensure long-term reliability and performance.

Controller Testing

Test the CSP-500x actuator's motor operation:

1. Temporarily disconnect the thermostat reset connection at Terminal "IN".
2. Jumper "IN" terminal to the "16 VDC" terminal. The green Open LED should illuminate. The shaft drive hub should be rotating the damper open. The damper should go to full open unless the maximum limit was set at the CSP-500x, and then the damper will only go to the maximum setting. If the damper is rotating closed, the "Close" jumpers must be changed. Refer to the Rotation Setup section.
3. Jumper "IN" terminal to the "-" terminal. The red Close LED should illuminate. The shaft drive hub should be rotating the damper closed. The damper should go to full closed unless the minimum limit was set at the CSP-500x, and then the damper will only go to the minimum setting. If the damper is rotating open, the "Close" jumpers must be changed. Refer to Rotation Setup section.

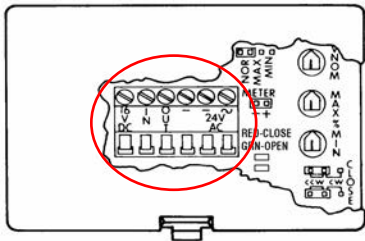

NOTE: For system testing guidelines and sample applications, see the [CSP-5001/5002 Application Guide](#).

Rotation Setup

The CSP-5001 is factory-set for CCW to close. The CSP-5002 is factory-set for CW to close. To reverse the rotation direction of either controller model:

1. Remove the access door by pulling back on the door's tab and lifting upward.
2. Position both jumpers in either the CW or CCW positions as needed. See the diagram.

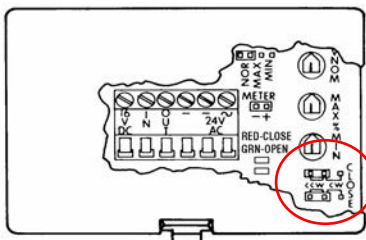

Specifications

Supply Voltage	24 VAC (-15/+20%), 50/60 Hz, Class 2 only (4 VA max.)
Output Supply	16 VDC (22 mA) to thermostat
Output Torque	50 in-lb. min., 70 in-lb. max.
Velocity Range	0 to 3300 fpm, dependent on DP pickup, tubing size/length, and connections
Signal Output	0 to 10 VDC (0 to 100% flow)
Signal Input	0 to 10 VDC (from thermostat)
Min./Max. Limits	Adjustable, 0 to 100%
Angular Rotation	0° to 95° (both end stops adjustable)
Stroke Time	18° per minute @ 60 Hz
Temperature Limits	
Operating	32 to 120° F (0 to 49° C)
Shipping	-40 to 140° F (-40 to 60° C)

More Information

For complete specifications and list of accessories, see the [CSP-5001/5002 Data Sheet](#) on the KMC web site.



For system testing guidelines, sample applications, and other information about usage with the CTE-5100 series thermostats, see the [CSP-5001/5002 Application Guide](#).

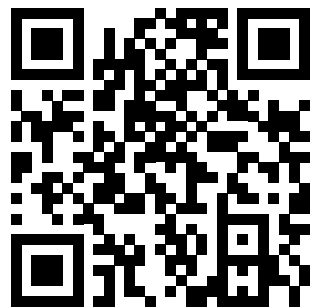

For information about connections and usage with newer CTE-5202 thermostats, see the [CTE-5202 Applications Guide](#).

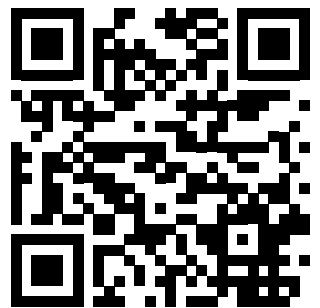

Controller Calibration

Minimum and Maximum Flow Limits

Minimum and maximum flow limits are often set at the thermostat. (For instructions on setting the flow limits at the thermostat and other information, see the [CSP-5001/5002 Application Guide](#) or [CTE-5202 Applications Guide](#).)

If desired, the minimum and maximum limits can be defined by adjusting the appropriate setpoints within the CSP-500x controller (see below) instead, but **do not try to set the limits at BOTH the controller and the thermostat (or else the limits will not reflect either the controller's or the thermostat's limits).**

To set the velocity limits at the CSP-500x:

1. Remove the access door by pulling back on the door's tab and lifting upward.
2. Connect a voltmeter to the meter taps (using HSO-5001 test leads).
3. Move the jumper from the NOR (normal) position (two left-most pins) to the MIN position (two right-most pins).
4. Adjust the MIN potentiometer for the desired minimum voltage.

NOTE: MIN must be adjusted first.

5. Move the jumper to the MAX position (two center pins).
6. Adjust the MAX potentiometer to the desired maximum voltage.
7. Return the jumper to the NOR position.

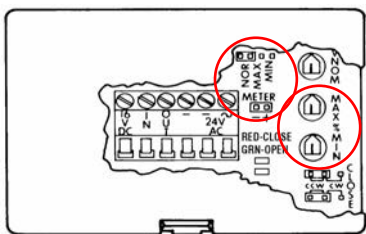

VNOM (CFM) Range Setting

NOTE: In the controller, VNOM stands for "NOMinal Volumetric flow rate."

The CSP-500x range is factory-calibrated with the VNOM potentiometer centered. Using any SSS-1000 series velocity pickup, tubing, and reducers, the CSP-500x will have a range of 0–3,300 fpm with a 0–10 VDC reset control signal from the thermostat.

Leaving the VNOM at the factory setting is recommended! Changing the VNOM potentiometer from the factory setting will alter the calibration between the "IN" and "OUT" voltages. However, the VNOM can be adjusted to match 0–10 volts to a specific velocity range if desired.

To set the VNOM range:

1. Remove the access door by pulling back on the door's tab and lifting upward.
2. Supply the desired velocity to the "H" and "L" ports.
3. Connect a voltmeter between the "OUT" and "-" terminals and adjust the VNOM potentiometer until the voltage equals 10 VDC.

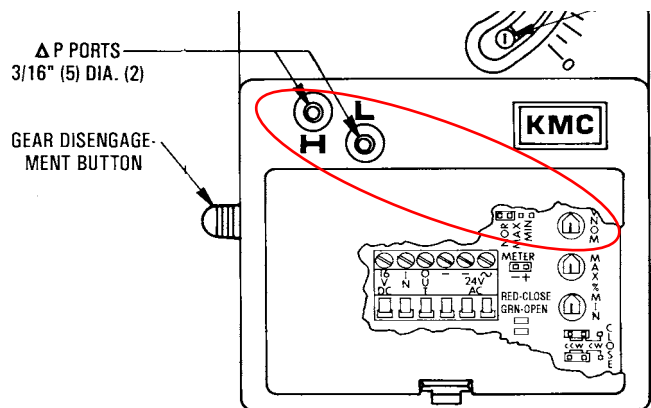

Important Notices

The material in this document is for information purposes only. **The contents and the product it describes are subject to change without notice.** KMC Controls, Inc. makes no representations or warranties with respect to this document. In no event shall KMC Controls, Inc. be liable for any damages, direct or incidental, arising out of or related to the use of this document.

KMC Controls, Inc.
19476 Industrial Drive
New Paris, IN 46553
574.831.5250
www.kmcccontrols.com
info@kmcccontrols.com