



**SIMPLY VAV**  
**DIRECT DIGITAL CONTROLS**  
PRE-PROGRAMMED  
FOR ALL BASIC VAV BOX  
CONTROL STRATEGIES

**DESCRIPTION**

The SimplyVAV series of controllers are an easy and unique approach to operating a wide variety of VAV terminal units. The integrated actuators, internal airflow sensors, and wide variety of application programs make these BACnet Application Specific controllers ideal for either new or retrofit installations.

**Simple, menu driven setup** The controllers feature simple, menu driven setup choices. No special programming skills or software tools are required to choose applications, enter setpoints, set network addressing, and balance airflow. All options can be set by using only an STE-8001 sensor which can be installed as the permanent room sensor or temporarily connected as a technician's service tool.

**New or retrofit applications** The SimplyVAV controllers are ideal for new installations or upgrades of older, less efficient controllers.

- Staged, modulated, floating, or time proportional reheat
- Series or parallel fan control
- Single or dual duct application

**Native BACnet** All models are BACnet Application Specific Controllers that are ready to connect to a BACnet MS/TP network. Device instance, MAC address, and baud rate are set from an STE-8001 without special software.

**Easy system integration** For SimplyVAV installations that are part of a BACnet building automation system, the controllers provide system diagnostic indicators. Through the MS/TP network, the controllers signal demands for higher static duct pressure, cooler or warmer supply air, and when to start air handler units.

**SPECIFICATIONS**

**Inputs and outputs**

All inputs and outputs for SimplyVAV controllers are set up at the factory and do not require field programming.

**Inputs**

- Sensors are automatically detected
- Inputs accept industry-standard 10K ohm thermistors sensors.
- Input overvoltage protection up to 24 volts AC, continuous.
- 12-bit analog-to-digital conversion

**Triac outputs**

- Optically isolated triac output.
- Maximum switching 24 volts AC at 1.0 ampere for each output
- Maximum for controller is 3.0 amperes.

**Analog outputs**

- Short-circuit protected
- Output voltage 0–10 volts DC
- 30 mA per output, 30 mA total for all analog outputs
- 12-bit digital-to-analog conversion

**Air flow sensor features**

CMOS differential pressure 0-2 inches of water (0-500 Pa) measurement range. Internally linearized and temperature compensated.

- Configured as BACnet analog input object.
- Span accuracy 4.5% of reading.
- Zero point accuracy 0.0008 in. H<sub>2</sub>O/0.2 Pa at 25° C
- Barbed connections for 1/4 inch FR tubing.

**Actuator features**

All models of SimplyVAV controllers include an integrated actuator.

<b>Torque</b>	40 in-lb. (4.5 N•m)
<b>Angular Rotation</b>	0 to 95° Adjustable end stops at 45 and 60° rotation

**Motor Timing**

BAC-8001,	90 sec./90° at 60 Hz
BAC-8005, and	108 sec./90° at 50 Hz
BAC-8007	
BAC-8205	60 sec./90° at 60 Hz

**Shaft size**

Directly mounts on 3/8 to 5/8 inch (9.5 to 16 mm) round or 3/8 to 7/16 inch (9.5 to 11 mm) square damper shafts.

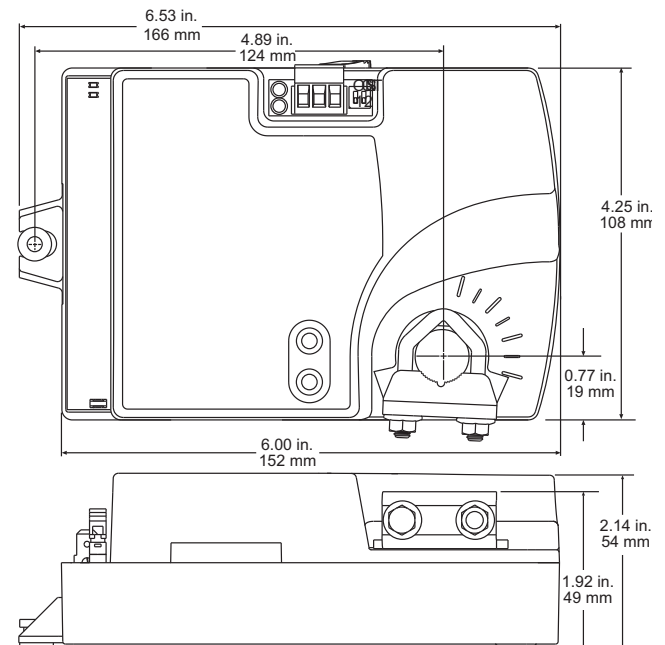

**JOB NAME:**

**SUBMITTED BY:**



**SIMPLY VAV**  
**DIRECT DIGITAL CONTROLS**  
PRE-PROGRAMMED  
FOR ALL BASIC VAV BOX  
CONTROL STRATEGIES

**Operating Sequences**

The following SimplyVAV models are supplied with factory included programs.

**BAC-8001**

Model BAC-8001 is supplied with inputs, outputs, and sequences of operation for the following functions.

- Single duct heating and cooling VAV
- Automatic heating/cooling changeover including morning warmup
- Occupancy setback—requires STE-8201
- System diagnostic indicators
- Airflow balancing

**BAC-8005 and BAC-8205**

Models BAC-8005 and BAC-8205 are supplied with inputs, outputs, and sequences of operation for the following functions.

- Single duct heating and cooling VAV
- Modulating, floating, time proportional, and staged reheat
- Series and parallel fan control
- Automatic heating/cooling changeover including morning warmup
- Discharge air temperature limiting
- Occupancy setback—requires STE-8201
- Actuator position feedback for true damper positioning (BAC-8205 only)
- System diagnostic indicators
- Airflow balancing

**BAC-8007**

Model BAC-8007 is supplied with inputs, outputs, and sequences of operation for the following functions.

- Dual-duct VAV heating and cooling
- Occupancy setback—requires STE-8201
- System diagnostic indicators
- Airflow balancing
- Uses TSP-8001 for secondary damper control

**BACnet communication**

- Integrated peer-to-peer BACnet MS/TP network communications.
- Network speed from 9600 to 76,800 baud

**INSTALLATION**

<b>Supply voltage</b>	24 volts AC (–15%, +20%), 50-60 Hz, 5 VA, Class 2 only
<b>Weight</b>	13.2 ounces (376 grams)
<b>Case material</b>	Gray and black flame retardant plastic
<b>Environmental limits</b>	
<i>Operating</i>	32 to 120° F (0 to 49° C)
<i>Shipping</i>	–40 to 140° F (–40 to 60° C)
<i>Humidity</i>	0-95% relative humidity (non-condensing)

**Regulatory**

- UL 916 Energy Management Equipment
- BACnet Testing Laboratory listed as Application Specific Controller (ASC)
- CE compliant
- SASO PCP Registration KSA R-103263
- FCC Class B, Part 15, Subpart B and complies with Canadian ICES-003 Class B



**ACCESSORIES**

**SimplyVAV digital sensors**

STE-8001W80	SimplyVAV sensor and digital display
STE-8201W80	SimplyVAV sensor and digital display with motion sensor

**SimplyVAV discrete temperature sensors**

STE-6010W80	Temperature sensor with RJ-45 connector
STE-6014W80	Temperature sensor with rotary setpoint dial, RJ-45 connector
STE-6017W80	Temperature sensor with rotary setpoint dial, override button, RJ-45 connector

**Dual duct actuator**

TSP-8001	VAV actuator with airflow inputs (required for dual duct)
----------	---

**JOB NAME:**

**SUBMITTED BY:**



**SIMPLY VAV**  
**DIRECT DIGITAL CONTROLS**  
PRE-PROGRAMMED  
FOR ALL BASIC VAV BOX  
CONTROL STRATEGIES

Model description	Model number
BACnet ASC: VAV Cooling/Heating, 40 in-lbs, 90 sec actuator	BAC-8001
BACnet ASC: VAV Fan and Reheat, 40 in-lbs, 90 sec actuator	BAC-8005
BACnet ASC: VAV Dual Duct, 40 in-lbs, 90 sec actuator	BAC-8007
BACnet ASC: VAV Fan and Reheat, Position, 40 in-lbs, 60 sec actuator	BAC-8205

### Controller selection guide

Models	Single duct heating and cooling	Dual duct heating and cooling	DAT limiting	1,2,3 staged reheat	Floating reheat	Modulating reheat	Time proportional reheat	Series fan	Parallel fan	True damper positioning	90 second rotation	60 second rotation
BAC-8001	◆										◆	
BAC-8005	◆		◆	◆	◆	◆	◆	◆	◆		◆	
BAC-8007		◆									◆	
BAC-8205	◆		◆	◆	◆	◆	◆	◆	◆	◆		◆

### Sensor selection guide

For sensor details see the data sheet for each sensor model.

Model	Temperature sensor	Setpoint dial	Override button	Setpoint buttons	Motion sensor	Digital display	Configuration tool	Balancing tool
STE-8001W80	◆			◆		◆	◆	◆
STE-8201W80	◆			◆	◆	◆	◆	◆
STE-6010W80	◆							
STE-6014W80	◆	◆						
STE-6017W80	◆	◆	◆					



<b>JOB NAME:</b>	<b>SUBMITTED BY:</b>
------------------	----------------------