

Anemostat®

SUBMITTAL

A MESTEK COMPANY

1220 Watson Center Road • Carson, CA 90745-4206
 (310) 835-7500 • FAX (310) 835-0448
 air@anemostat.com • www.anemostat.com



Model **F3P**

HINGED RETURN FILTER GRILLE

PERFORATED

9/16" NARROW SLOT

GRILLES & REGISTERS

PRODUCT FEATURES

- Perforated, 51% free area
- Piano Hinge Construction
- 1/4-Turn Latch(es). Qty=2 on size 24" & up
- Concealed fastening thru neck of grille
- Recommended Filter Size (Actual) = (Nom Width -1/2") x (Nom Height -1/2")

CONSTRUCTION DETAILS

Material:

- Steel
- Aluminum
- Stainless Steel

Finish:

- Arctic White
- Satin Polish
- Custom Color _____

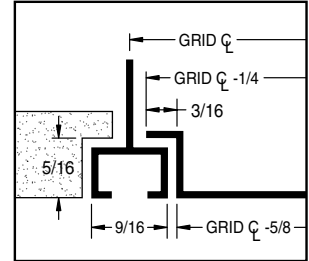

9/16 NARROW SLOT

AVAILABLE SIZES

MODULE SIZE	MAX NECK SIZE
12 x 12	10 x 10
12 x 24	10 x 22
24 x 24	22 x 22
24 x 48	22 x 46

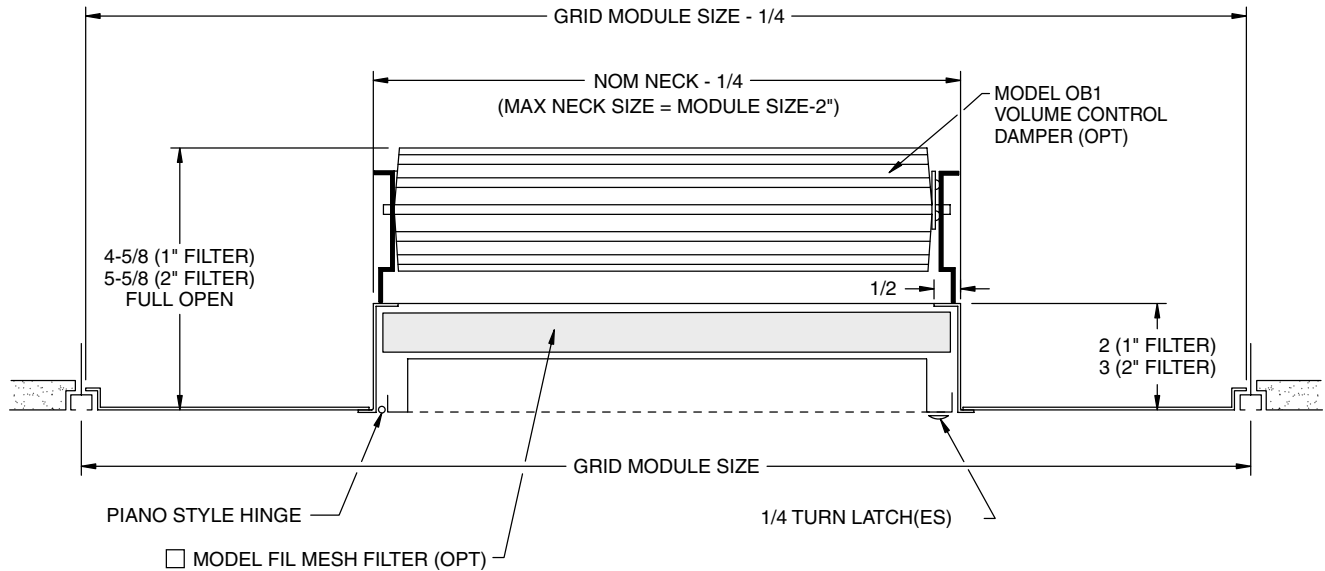

MODEL	FILTER SIZE	TYPE	DUCT (W X H)	APPLICATION	MODULE
F3P Perforated	1L	H Hinged Core	12.00 / 12.00	D 9/16" Narrow Slot	22
	1 1" Filter				- N/A
	2 2" Filter				11 12" x 12"
	1S 1" Filter, Hinge on Short Dim.				12 12" x 24"
	1L 1" Filter, Hinge on Long Dim.				22 24" x 24"
	2S 2" Filter, Hinge on Short Dim.				24 24" x 48"
	2L 2" Filter, Hinge on Long Dim.				

Dimensions are in inches (millimeters).

JOB NAME:

SUBMITTED BY: