

**Anemostat**<sup>®</sup>  
**SUBMITTAL**  
 A MESTEK COMPANY

1220 Watson Center Road • Carson, CA 90745-4206  
 (310) 835-7500 • FAX (310) 835-0448  
 air@anemostat.com • www.anemostat.com



Model **F3P**  
**HINGED RETURN FILTER GRILLE**  
 PERFORATED  
 TEGULAR

**GRILLES & REGISTERS**

**PRODUCT FEATURES**

- Perforated, 51% free area
- Piano Hinge Construction
- 1/4-Turn Latch(es). Qty=2 on size 24" & up
- Concealed fastening thru neck of grille
- Recommended Filter Size (Actual) = (Nom Width -1/2") x (Nom Height -1/2")

**CONSTRUCTION DETAILS**

**Material:**

- Steel
- Aluminum
- Stainless Steel

**Finish:**

- Arctic White
- Satin Polish
- Custom Color \_\_\_\_\_

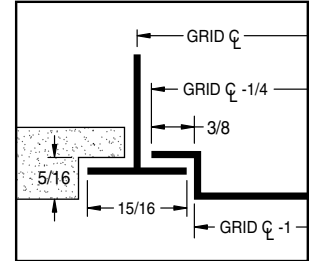

15/16" TEGULAR

**AVAILABLE SIZES**

MODULE SIZE	MAX NECK SIZE
12 x 12	10 x 10
12 x 24	10 x 22
24 x 24	22 x 22
24 x 48	22 x 46

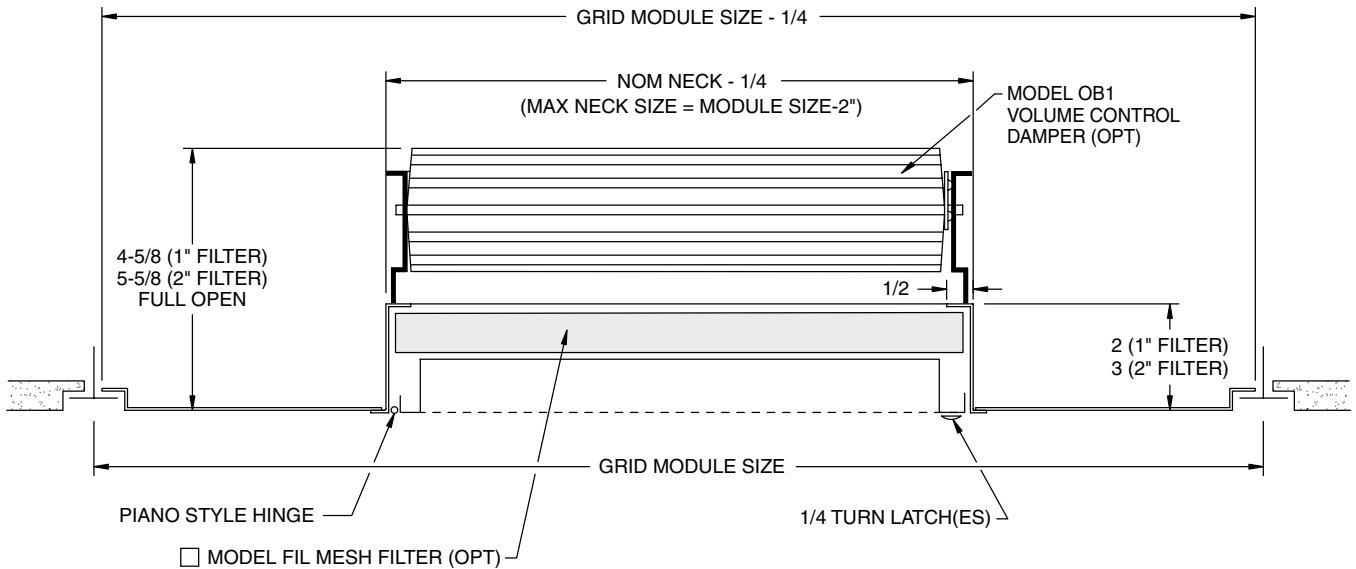

MODEL	FILTER SIZE	TYPE	DUCT (W X H)	APPLICATION	MODULE
<b>F3P</b> Perforated	<b>1L</b>	<b>H</b> Hinged Core	<b>12.00 / 12.00</b>	<b>T</b> Tegular	<b>22</b>
	1 1" Filter				- N/A
	2 2" Filter				11 12" x 12"
	1S 1" Filter, Hinge on Short Dim.				12 12" x 24"
	1L 1" Filter, Hinge on Long Dim.				22 24" x 24"
	2S 2" Filter, Hinge on Short Dim.				24 24" x 48"
	2L 2" Filter, Hinge on Long Dim.				

Dimensions are in inches (millimeters).

JOB NAME:

SUBMITTED BY: