



Anemostat®

SUBMITTAL

A MESTEK COMPANY

1220 Watson Center Road • Carson, CA 90745-4206
 (310) 835-7500 • FAX (310) 835-0448
 air@anemostat.com • www.anemostat.com



Model **FGC5**
HINGED RETURN FILTER GRILLE
 ALUMINUM GRID CORE
 1/2" x 1/2" x 1/2"
 LAY-IN T-BAR

GRILLES & REGISTERS

PRODUCT FEATURES

- Aluminum Grid Core, 1/2" x 1/2" x 1/2"
- Piano Hinge Construction
- 1/4-Turn Latch(es). Qty=2 on size 24" & up
- Concealed fastening thru neck of grille
- Sizes 6" x 4" to 48" x 48" maximum single piece construction
- Recommended Filter Size (Actual) = Grid Module Size -3-1/8"

CONSTRUCTION DETAILS

Material:

Steel

Finish:

Arctic White

Satin Polish

Custom Color _____

AVAILABLE SIZES	
MODULE SIZE	DUCT SIZE
12 x 12	10 x 10
12 x 24	10 x 22
24 x 24	22 x 22
24 x 48	22 x 46

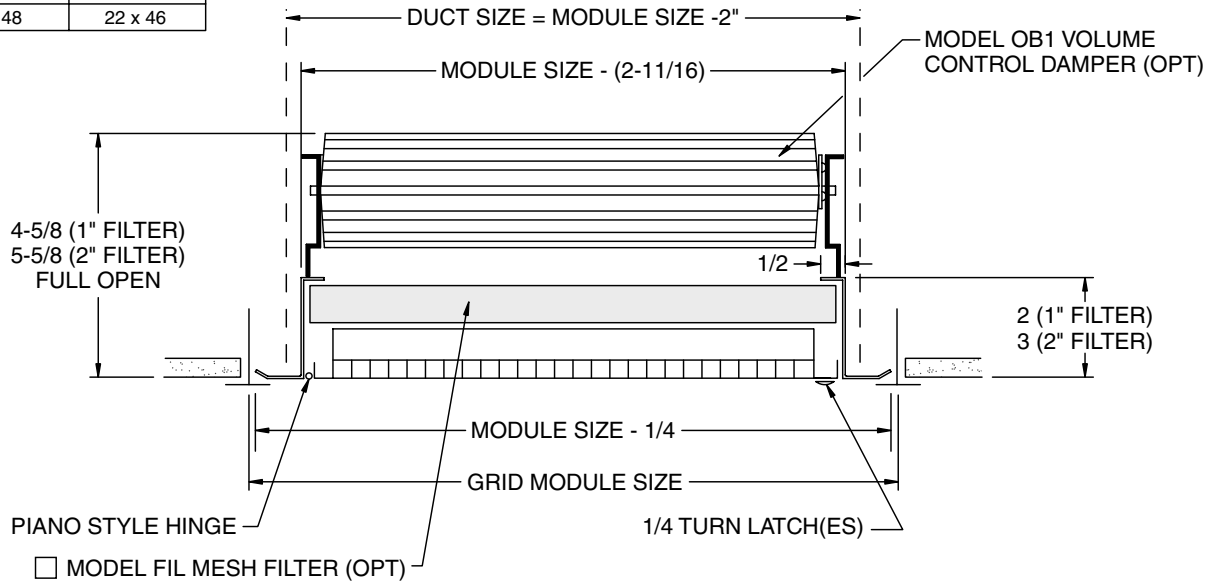

MODEL	FILTER SIZE	TYPE	DUCT (W X H)	APPLICATION	MODULE
FGC5	1L	H	22.00 / 22.00	L	22
Aluminum Grid Core	1 1" Filter 2 2" Filter 1S 1" Filter, Hinge on Short Dim. 1L 1" Filter, Hinge on Long Dim. 2S 2" Filter, Hinge on Short Dim. 2L 2" Filter, Hinge on Long Dim.	Hinged Core		Inverted T-Bar, 15/16"	- N/A 11 12" x 12" 12 12" x 24" 22 24" x 24" 24 24" x 48"

Dimensions are in inches (millimeters).

JOB NAME:

SUBMITTED BY: