

SUBMITTAL SHEET

PRODUCT FEATURES

- 1/2" x 1/2" x 1/2" aluminum core
- Registers include a factory attached, steel opposed blade volume control damper

CONSTRUCTION DETAILS

Material: All Steel Components with Aluminum Core (**std**)

Finish:

- Arctic White (**std**)
- Custom Color (opt)

Extension Panel

- A** 06" x 30" Module
- B** 06" x 48" Module
- 11** 12" x 12" Module
- 12** 12" x 24" Module
- 22** 24" x 24" Module
- 24** 24" x 48" Module
- 30** 30" x 30" Module

Accessories

- OB** Opposed Blade Damper

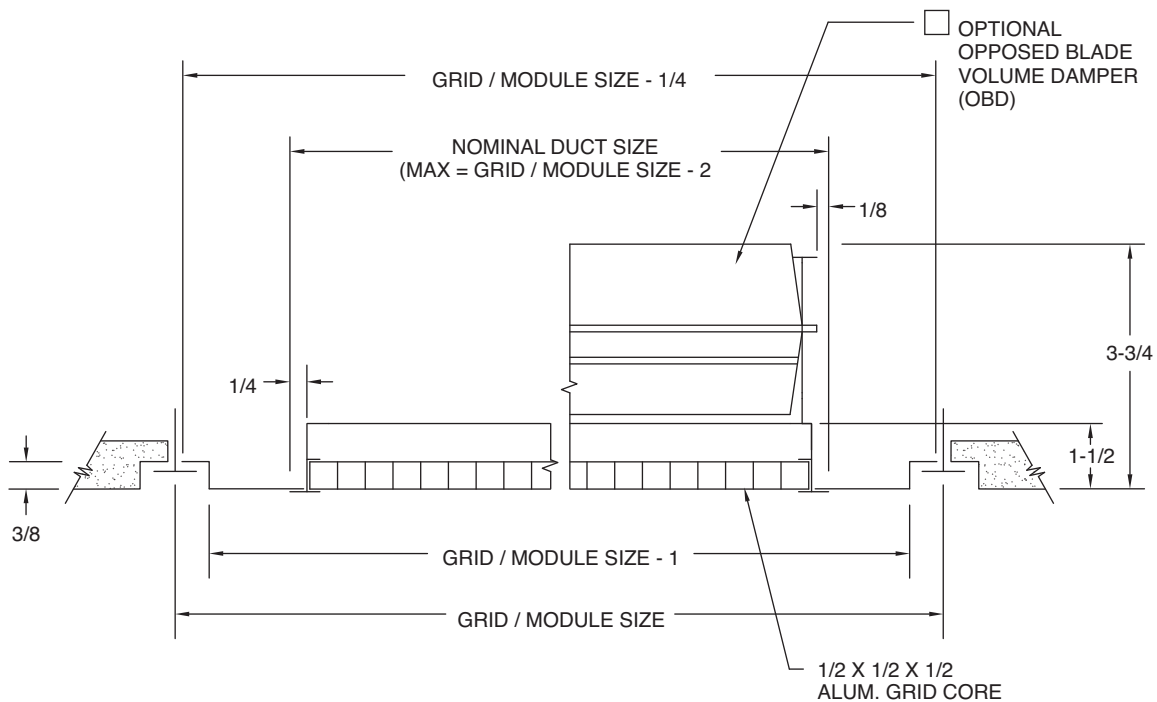

GRID / MODULE SIZE	MAX NECK SIZE
12 x 12	10 x 10
12 x 24	10 x 22
24 x 24	22 x 22
24 x 48	22 x 46
48 x 48	46 x 46

All dimensions are in inches.

JOB NAME:

SUBMITTED BY: