

SUBMITTAL SHEET

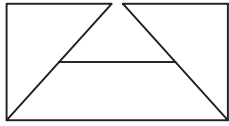

®

from: **ANEMOSTAT**®

CARSON CA
310-835-7500

**MODEL
ADL**
ADJUSTABLE
'Z' BLADE
LOUVER

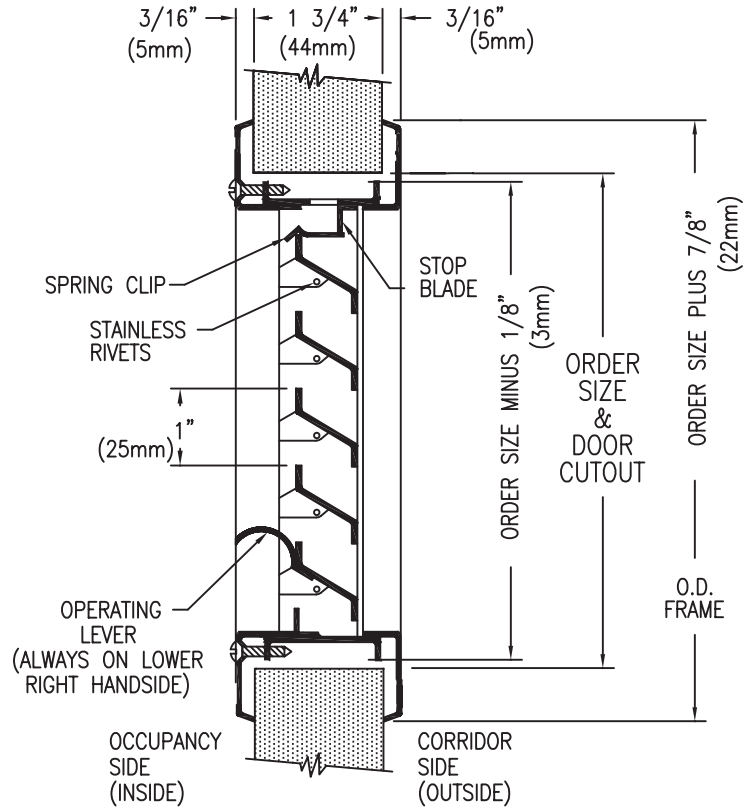
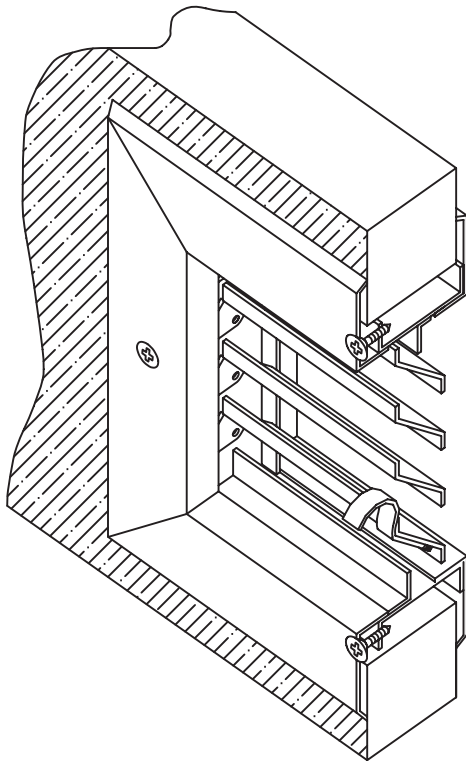

All Dimensions $\pm 1/32$

STANDARD PRODUCT FEATURES

- MATERIAL: 18 GA. Cold Rolled Steel, Frame and Louver Blades.
- FINISH: Arctic White, Baked-On
- INSTALLATION: Self attaching using #8 x 1" phillips head screws that fasten the auxiliary frame to the louver core, thru the cutout in the door. The corridor side of the frame is free of fasteners for added security.
- DOOR THICKNESS: For 1 3/4" Door.
(available for 1 3/8" Doors).
- AESTHETICS: Tight mitered corners and countersunk mounting holes make for a clean appearance.
- USES: Where an adjustable louver without a fire rating is required.
- FREE AIR FLOW: 40% Free Area.
- NOTE: For Exterior use, High Humidity or Salt Air application, product must be Galvanized or Stainless Steel.

OPTIONAL FEATURES

- MATERIAL: #304 Stainless Steel, #4 Finish (Satin), Galvanized (Sheet or Zinc Plated).
- FINISH: Special order Baked Enamel Colors (as per sample chip supplied by customer).
- FASTENERS: Special Security Screw Fasteners, See Page 10, this section.
- SPECIALS: Fractional sizes not available.
18-14 mesh insert screens, loose or attached. (Galvanized, Aluminum, Charcoal Aluminum, Stainless Steel).

FIRE RATINGS (with U.L. classification marking)

- ADL is not fire rated.

All Dimensions are in Inches

JOB NAME:	SUBMITTED BY:
LOCATION:	
ARCHITECT:	
ENGINEER:	DWG # LOV-0004
CONTRACTOR:	DATE 6-15-05 REV C

544A100CA1