



Anemostat®
AIR DISTRIBUTION

MODEL **LA450DM**

EXTRUDED ALUMINUM LOUVERS
ADJUSTABLE TYPE 4" DEEP

DRAIN LOUVER - CONCEALED ACTUATOR

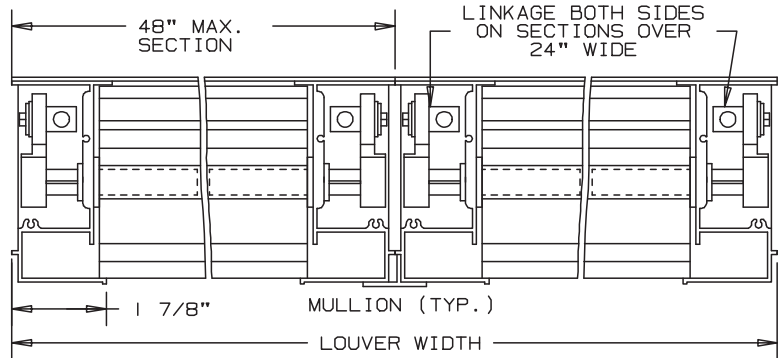
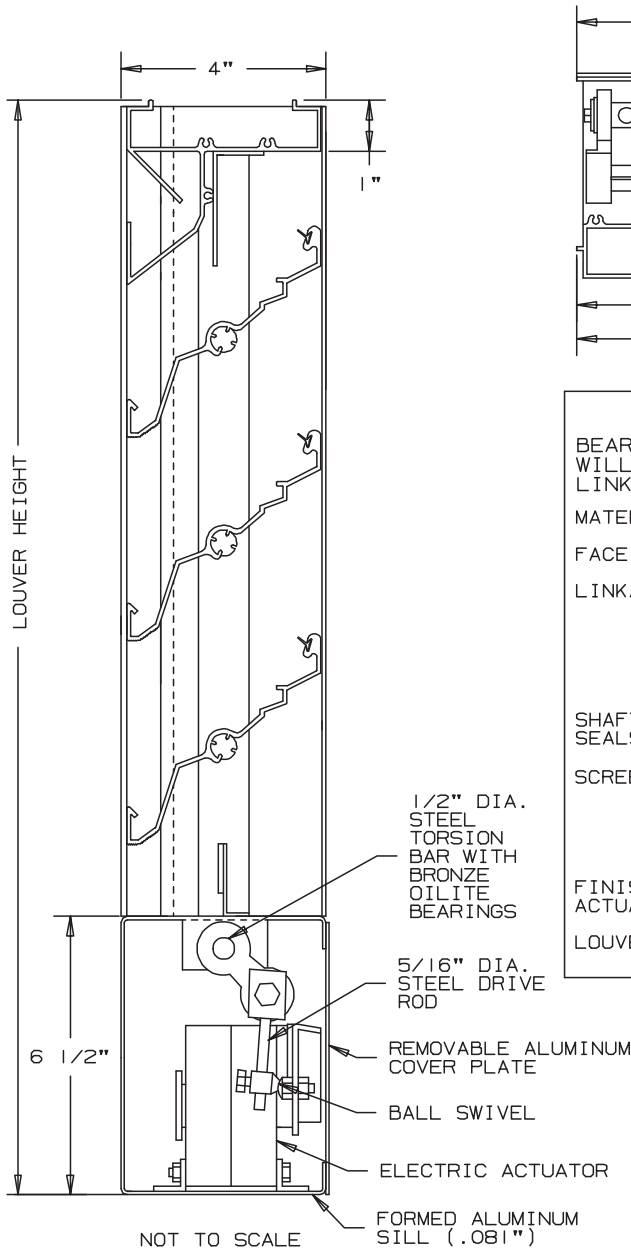

SPECIFICATIONS

BEARINGS: CELCON BEARING MATERIAL SO THAT THERE WILL BE NO METAL TO METAL FRICTION. OPERATING LINKAGE CONCEALED IN FRAME, OUT OF THE AIR STREAM.

MATERIAL: FRAME AND BLADE EXTRUDED ALUMINUM 6063-T6/T52 ALLOY .080" THK., BLADES ON 4" CENTERS.

FACE OF LOUVER: FULL WIDTH SILL WITH DRAIN HEAD AND DRAIN BLADES CONTAINED WITHIN THE DRAIN JAMBS.

LINKAGE: EXTRUDED ALUMINUM, CONCEALED IN CHANNEL OUT OF AIRSTREAM. PIVOTS ARE .50" DIA. MACHINED STEEL, CADMIUM PLATED AND CHROMATE TREATED. PIVOTS ROTATE IN A CELCON BEARING. A .312" DIA. ALUMINUM LINKAGE ROD IS LOCKED TO THE PIVOT BY A 1/4-20 SET SCREW WITH AN EPOXY LOCKING PATCH.

SHAFTS: .50" DIA. ALUMINUM "PIN-LOCK" ROD.

SEALS: EXTRUDED SILICONE RUBBER SEAL AT BLADE EDGE. POLYURETHANE AT THE JAMBS.

SCREENS: WHEN INDICATED, IN A REMOVABLE FRAME.
 BIRD SCREEN - 1/2" FLATTENED ALUMINUM, .051" THK.
 OR - 1/2" SQ. MESH, INTERMEDIATE DOUBLE-CRIMPED ALUMINUM WIRE, .063 DIA.
 OR - 18/16 MESH, .011" DIA. ALUMINUM WIRE, INSECT SCREEN.

FINISH: MILL.

ACTUATOR: 120 VAC, SPRING RETURN NORMALLY CLOSED
 133 IN-LBS. TORQUE.

LOUVER SIZES: 12" x 19" MINIMUM PANEL SIZE.
 48" x 96" MAXIMUM PANEL SIZE.

OPTIONAL

- * OTHER SCREENS
- * ARCHITECTURAL FINISHES

NOMINAL DEDUCTIONS WILL BE MADE TO THE OPENING SIZES GIVEN.

ITEM	QTY.	OPENING SIZE		LOUVER SIZE		MULL	SCREENS	
		WIDTH	HEIGHT	WIDTH	HEIGHT		TYPE	LOC



Anemostat Air Distribution
 1220 E. Watson Center Road
 Carson, CA 90745
 310-835-7500 • air@anemostat.com
 www.anemostat-hvac.com

AGENT: _____

ARCH./ENG. : _____

CONTR. : _____

PROJECT : _____

EDR: _____ ECN: _____ JOB: _____

DATE: _____ DWN. : _____ DWG. : _____