



Anemostat
AIR DISTRIBUTION

MODEL **LS200**

FORMED STEEL LOUVERS
2" DEEP

45° STANDARD BLADE - STATIONARY

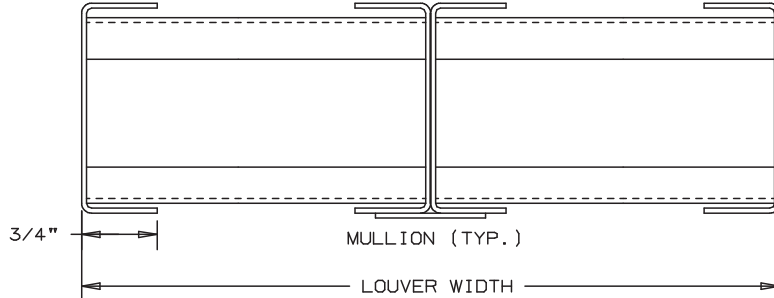
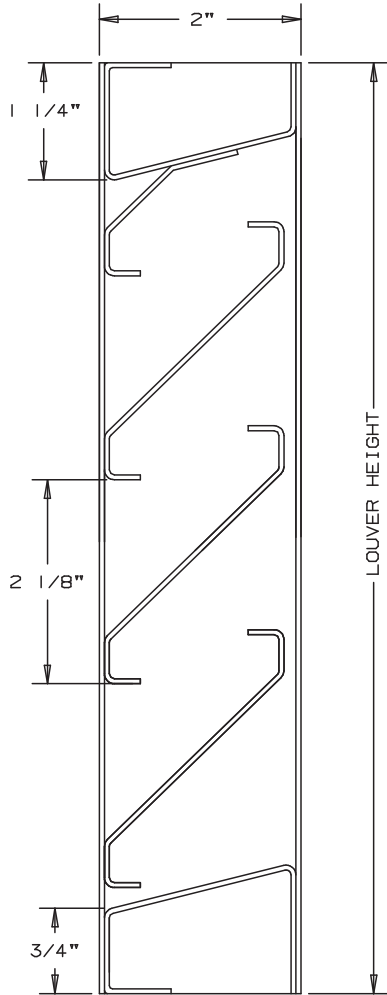

SPECIFICATIONS

FRAME: 18 GA. GALVANIZED STEEL CHANNEL OR FLANGED.
 BLADES: 18 GA. GALVANIZED STEEL.
 SCREEN: (WHEN INDICATED)
 - 1/2" SQ. MESH, 19 GA. GALVANIZED STEEL (.041").
 CONSTRUCTION: RIVETED AND/OR WELDED, FOR MAXIMUM SERVICE.
 FINISH: _____

OPTIONAL

FRAMES AND BLADES OF OTHER GAUGES.
 OTHER MATERIALS: STAINLESS STEEL, COPPER, ALUM., ETC.
 FINISHES: ENAMELS, EPOXIES, ETC.
 SCREENS: INSECT SCREEN 18/16 ALUMINUM MESH
 1/2" FLATTENED ALUMINUM .051"
 1/4" SQ. MESH 18 GA. GALVANIZED STEEL, .047"
 1/2" SQ. MESH 18 GA. STAINLESS STEEL, .047"
 PLUS OTHERS

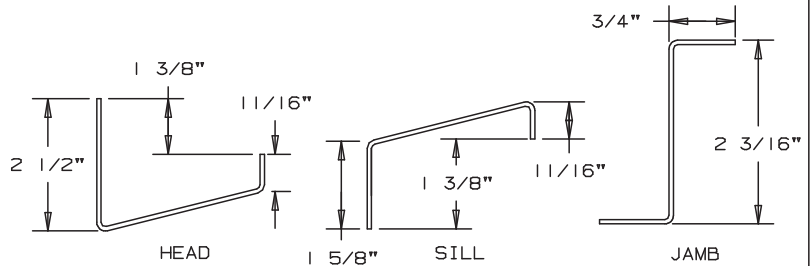

NOMINAL DEDUCTIONS WILL BE MADE TO THE OPENING SIZE GIVEN.

FLANGE FRAME AVAILABLE

ITEM	QTY.	WIDTH	HEIGHT	WIDTH	HEIGHT	MULL	TYPE	LOC	SCREENS	
		OPENING SIZE		LOUVER SIZE						

Anemostat Air Distribution
 1220 E. Watson Center Road
 Carson, CA 90745
 310-835-7500 • air@anemostat.com
 www.anemostat-hvac.com

AGENT: _____

ARCH./ENG. :
CONTR. :
PROJECT :
EDR: ECN: JOB:
DATE: DWN. : DWG. :