



Anemostat®

SUBMITTAL

A MESTEK COMPANY

1220 Watson Center Road • Carson, CA 90745-4206
 (310) 835-7500 • FAX (310) 835-0448
 airhelp@anemostat.com • www.anemostat.com

Model **MVCF**

PERIMETER AIR CURTAIN

FOR AORTA

OPERATING ROOM SYSTEMS

WITH HEPA FILTER - SIDE INLET

DIFFUSERS

PRODUCT FEATURES

- Perimeter diffuser establishes an outward air curtain between a 5°-15° discharge angle
- Fixed pattern created by stamped control flaps for predictable performance – outperforms slot configurations for directional control
- Filter interface includes knife edge into filter gel seals for zero leak performance
- 4 capacity ranges available for extreme design flexibility - system 31, 42, 53, and 64
- Dual chamber design means stable performance regardless of inlet condition or damper position.
- Removable face via 1/4 turn fasteners for cleaning
- Face is hinged and swings down 90° for easy cleaning. Safety cables prevent face from accidentally swinging down.
- Closed cell gasket prevents leakage around face

MATERIAL AND FINISH

Face:

- Steel with White Baked Epoxy
- Aluminum with White Baked Epoxy
- 304 Stainless Steel, #4 Polish
- 304 Stainless Steel with White Baked Epoxy

Backpan / Plenum:

- Steel with White Baked Epoxy
- Aluminum with White Baked Epoxy
- 304 Stainless Steel, 2B Mill Finish
- 304 Stainless Steel with White Baked Epoxy

MODELS

- MVCF-T** Lay-In T-Bar (Side Inlet)
- MVCF-P** Surface Mounted (Side Inlet)

CAPACITY

- 31 53
- 42 64

ACCESSORIES

- Light Alert** Filter Monitoring System

MVCF DIMENSIONS	
Nom. Length	Nom. Duct Size
24	
36	12 x 6
48	18 x 6
60	24 x 6
72	

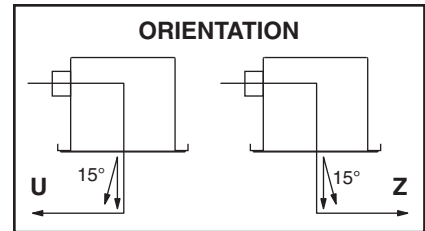

Model MVCF-T

Lay-In T-Bar
(Side Inlet)

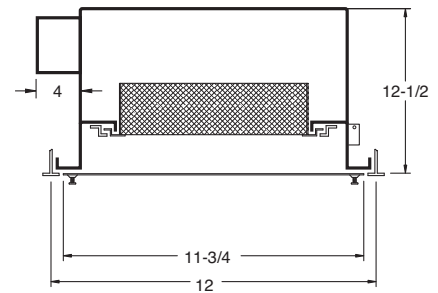
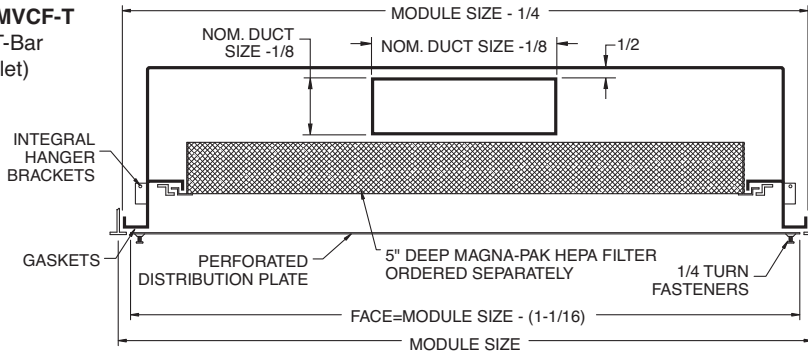

Model MVCF-P

Surface Mounted

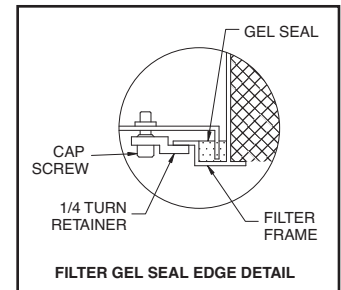
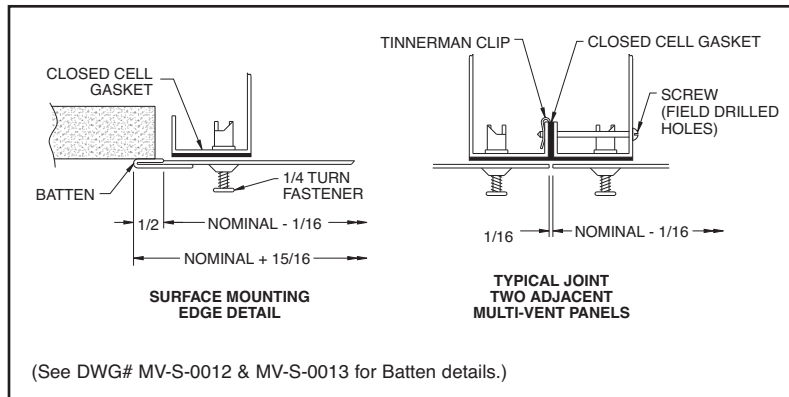

All dimensions are in inches.

JOB NAME:

SUBMITTED BY: