

Anemostat® SUBMITTAL

1220 Watson Center Road • Carson, CA 90745-4206
 (310) 835-7500 • FAX (310) 835-0448
 air@anemostat.com • www.anemostat-hvac.com

Model **QC-L** MODULAR CORE DIFFUSER WITH EXTENSION PANEL LAY-IN T-BAR

DIFFUSERS

PRODUCT FEATURES

- Flexible, modular core supply diffuser for horizontal air distribution patterns.
- Diffuser with (4) Cores easily re-configured in field for desired air distribution pattern (1, 2, 3 or 4-way)
- Spring loaded cores

Note: Diffuser ships with 4-way pattern

AVAILABLE DUCT SIZES	OPTIONAL SRA MAX Ø
6 x 6	6" Ø
8 x 8	8" Ø
10 x 10	10" Ø
12 x 12	12" Ø
14 x 14	14" Ø
16 x 16	16" Ø
18 x 18	18" Ø
20 x 20	20" Ø

GRID MODULE SIZE	MAX NECK SIZE
12 x 12	8 x 8
12 x 24	8 x 8
24 x 24	20 x 20
24 x 48	20 x 20

CONSTRUCTION DETAILS

Diffuser:

- Steel
- Aluminum

Extension Panel:

- Steel
- Aluminum

Finish:

- Arctic White Baked Finish
- Custom Colors

MODELS

- QC-L** (Lay-in 15/16 T-Bar)

ACCESSORIES

- OB1S** (Steel Opposed Blade Volume Control Damper)
- OB1X** (Aluminum Opposed Blade Volume Control Damper)
- SRA** Square to Round Adapter, Steel
- VD** Volume Damper, Butterfly Type, Steel (used with SRA)

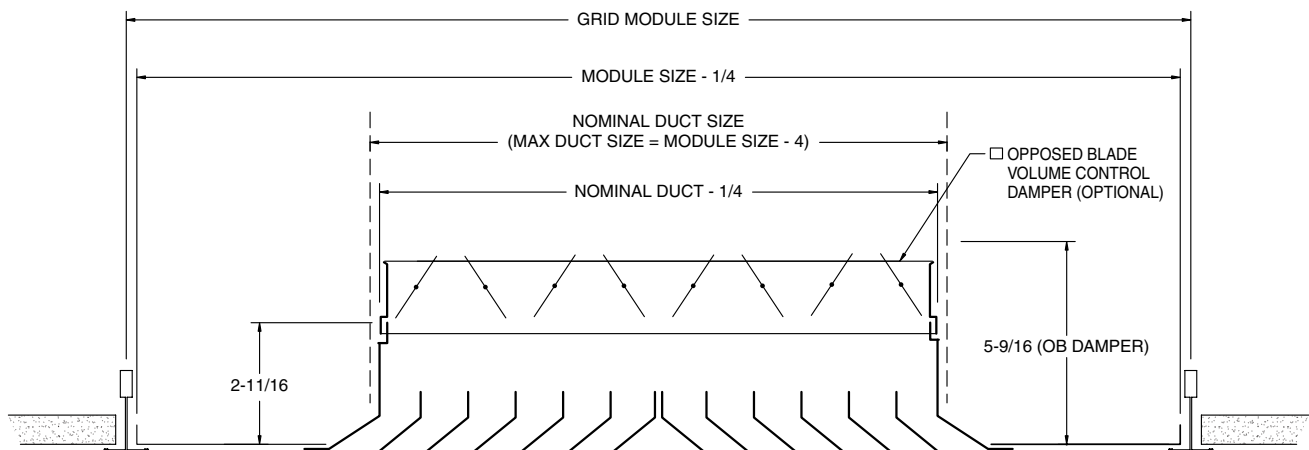

CORE PATTERNS

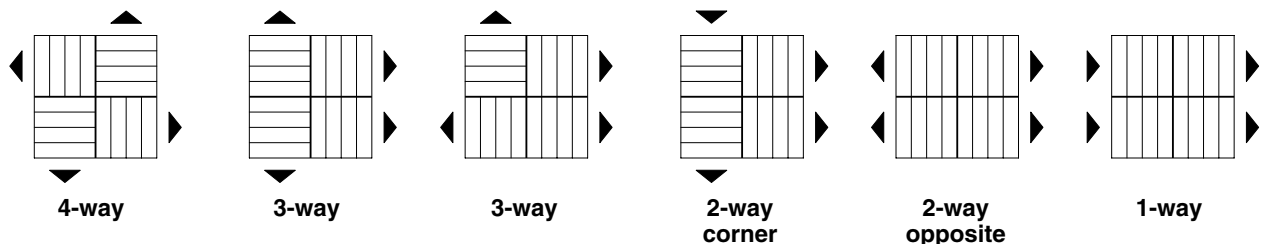

All dimensions are in inches.

JOB NAME:

SUBMITTED BY: