



PRODUCT FEATURES

- 1,2,3, or 4 parallel slots integrated into a coated steel plenum for return applications
- Matching return for Model SCD Supply Diffuser
- 3/4", 1", 1-1/2" slot widths
- 24", 36", 48", 60" nominal lengths

CONSTRUCTION DETAILS

- Material:** 24 GA Zinc-Coated Steel
Finish: Flat black on exposed Diffuser Face surfaces (**std**)
Factory attached T-Bars are white
- Custom Colors (opt)

MODELS

- SCR-L9** All center Tees included
- SCR-L9-N** 2' x 2' Crossover, All center Tees included (notch in center of 4' plenum)
- SCR-L9X** Straddle (2 slot only - NO center Tee). Unit includes notched end caps for grid member.
- SCR-L9X-N** Combination Crossover and Straddle feature (2 slot only)

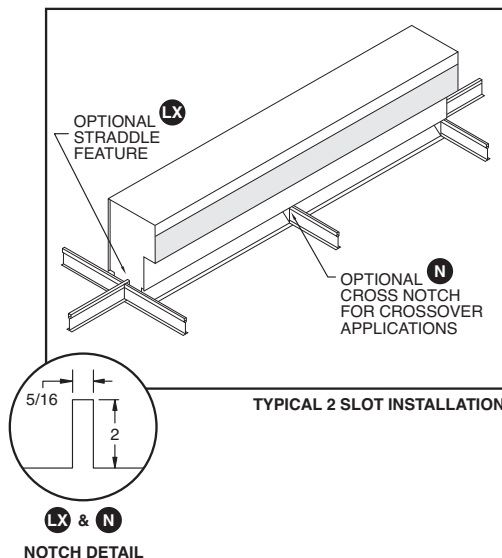
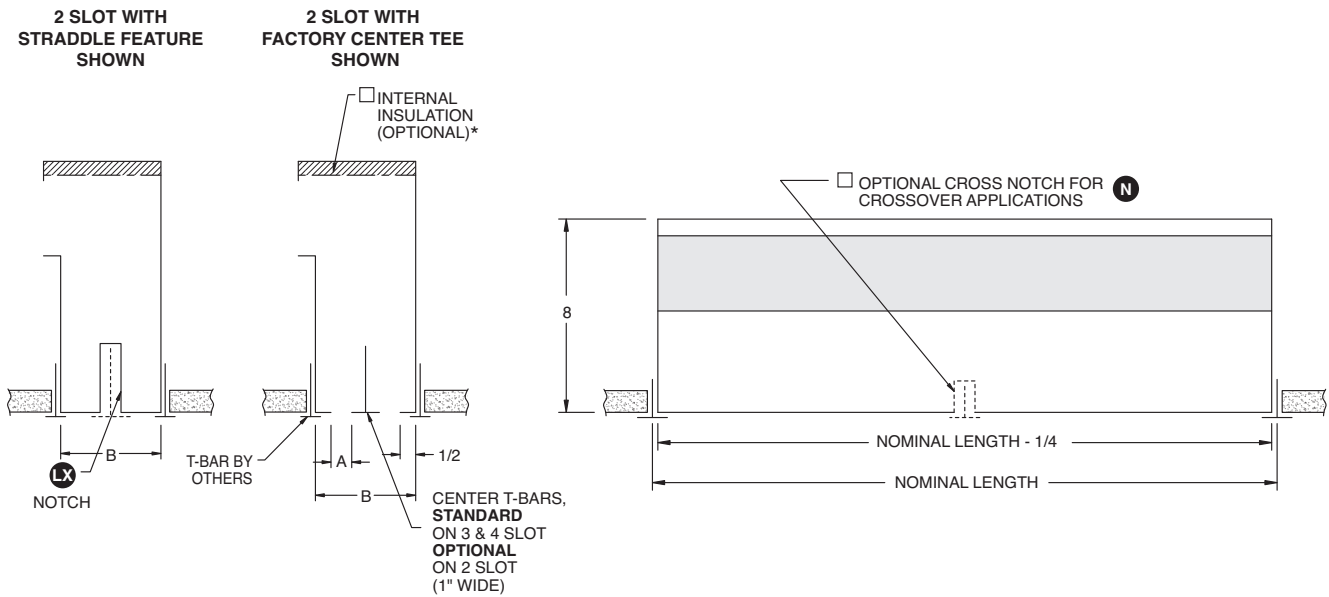

	SLOT WIDTH A	B				NOM LENGTH
		1-SLOT	2-SLOT	3-SLOT	4-SLOT	
SCR-75	3/4"	1-3/4	3-1/2	5-1/4	7	24, 30, 36, 48, 60
SCR-10	1"	2	4	6	8	
SCR-15	1-1/2"	2-1/2"	5	7-1/2	10	

All dimensions are in inches.

JOB NAME:

SUBMITTED BY:

FACTORY INSTALLED SIDE TEES / CLIPS
(FACTORY TEES ARE 1" WIDE - WHITE FINISH)

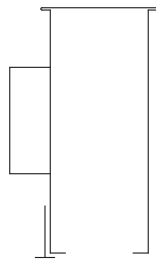

OPTION 1
ONE SIDE TEE
(INLET SIDE)

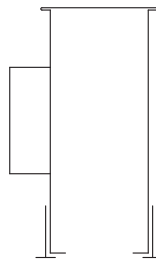

OPTION 2
TWO SIDE TEE

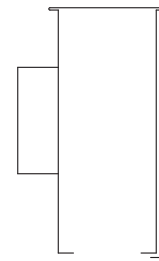

OPTION 3
ONE SIDE TEE
(NON-INLET SIDE)

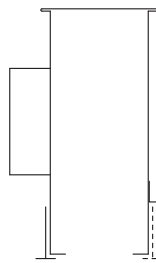

OPTION A
ONE SIDE TEE
(INLET SIDE)
+ T-BAR CLIPS

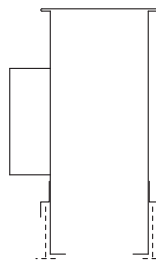

OPTION B
T-BAR CLIPS
(BOTH SIDES)

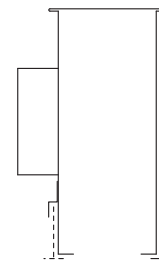

OPTION C
ONE SIDE TEE
(NON-INLET SIDE)
+ T-BAR CLIPS

GRID / CEILING TYPE

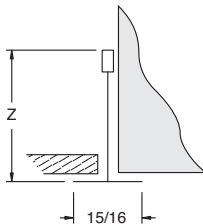

15/16" LAY-IN

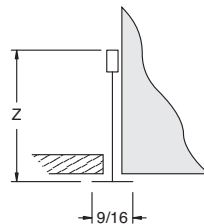

9/16" LAY-IN

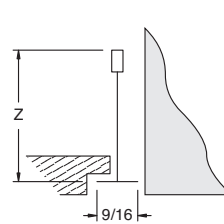

9/16" TEGULAR

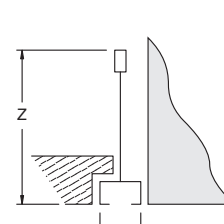

9/16" NARROW SLOT

CEILING MANUFACTURER: _____

Z = _____

MODEL: _____

All dimensions are in inches.

JOB NAME: _____

SUBMITTED BY: _____