



# Anemostat® SUBMITTAL

1220 Watson Center Road • Carson, CA 90745-4206  
(310) 835-7500 • FAX (310) 835-0448  
air@anemostat.com • www.anemostat-hvac.com

Models **SPT-S / SPTN-S**  
**PUNKAH TYPE**  
**SPOT DIFFUSER**  
**SURFACE MOUNTED**

## DIFFUSERS

### PRODUCT FEATURES

- Field adjustable directional control up to 75° total angle
- Includes screw holes and factory supplied screws
- Integral volume control damper changes effective nozzle area while maintaining jet discharge velocity. Knurled adjustment knob means no tools required

### CONSTRUCTION DETAILS

- Material:** Aluminum  
**Finish:** Clear Anodize (std)  
 Custom Colors (opt)

### Models

- SPT-S**  
With Volume Control Damper  
 **SPTN-S**  
Without Volume Control Damper

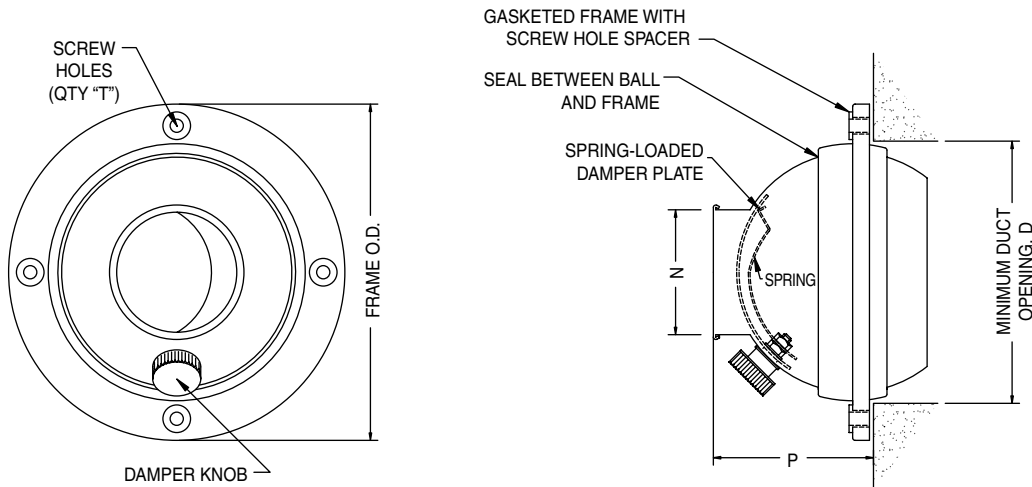

MODEL	MINIMUM DUCT OPENING, D	FRAME O.D.	P	N, Ø	T	MODEL
SPT-S-3	3-3/8	4-9/16	2-1/8	1-1/2	3	SPTN-S-3
SPT-S-4	4-3/8	5-1/2	2-9/16	2	4	SPTN-S-4
SPT-S-5	5-1/2	6-11/16	3-1/4	2-9/16	5	SPTN-S-5
SPT-S-6	6-5/16	7-1/2	3-11/16	2-15/16	5	SPTN-S-6
SPT-S-7	7-1/2	9-1/8	4-3/8	3-9/16	5	SPTN-S-7
SPT-S-8	8-3/16	9-7/8	4-3/4	3-15/16	5	SPTN-S-8
SPT-S-10	11-1/16	12-3/4	6-7/8	5-1/2	5	SPTN-S-10
SPT-S-12	12-9/16	14-5/16	7-7/8	6-1/2	5	SPTN-S-12
SPT-S-16	16-3/4	18-1/2	9-3/4	9-1/16	8	SPTN-S-16
SPT-S-18	19-1/8	21-1/16	11-5/8	10-1/4	8	SPTN-S-18
SPT-S-20	19-1/8	21-1/16	11-5/8	12-1/4	8	SPTN-S-20

All dimensions are in inches.

JOB NAME:

SUBMITTED BY: