



Anemostat®

AIR DISTRIBUTION

SUBMITTAL SHEET

www.anemostat-hvac.com



Model **SC-BCL**
SLAB CORE PANEL SYSTEM
CORNER LOCK

PRODUCT FEATURES

- Solid, underfoot feel and sound
- Bare-corner/bolted stringer & bolted corner assembly options
- Conductive ground path from the panel to the pedestal
- Higher combustibility rating than standard wood core panel
- Over-sized panels available for perimeter applications

CONSTRUCTION FEATURES

Material:

Cementitious treated wood core & galvanized steel composite design

Finish:

- Carpet Tile
- High Pressure Laminate
- Conductive / Dissipative Vinyl
- Other : _____

MODELS

- SC1000-BCL** Design Load 1000 lbs.
- SC1000-BCL-C** Design Load 1000 lbs.
CISCA Rated
- SC1250-BCL** Design Load 1250 lbs.
- SC1250-BCL-C** Design Load 1250 lbs.
CISCA Rated
- SC1500-BCL** Design Load 1500 lbs.
- SC1500-BCL-C** Design Load 1500 lbs.
CISCA Rated

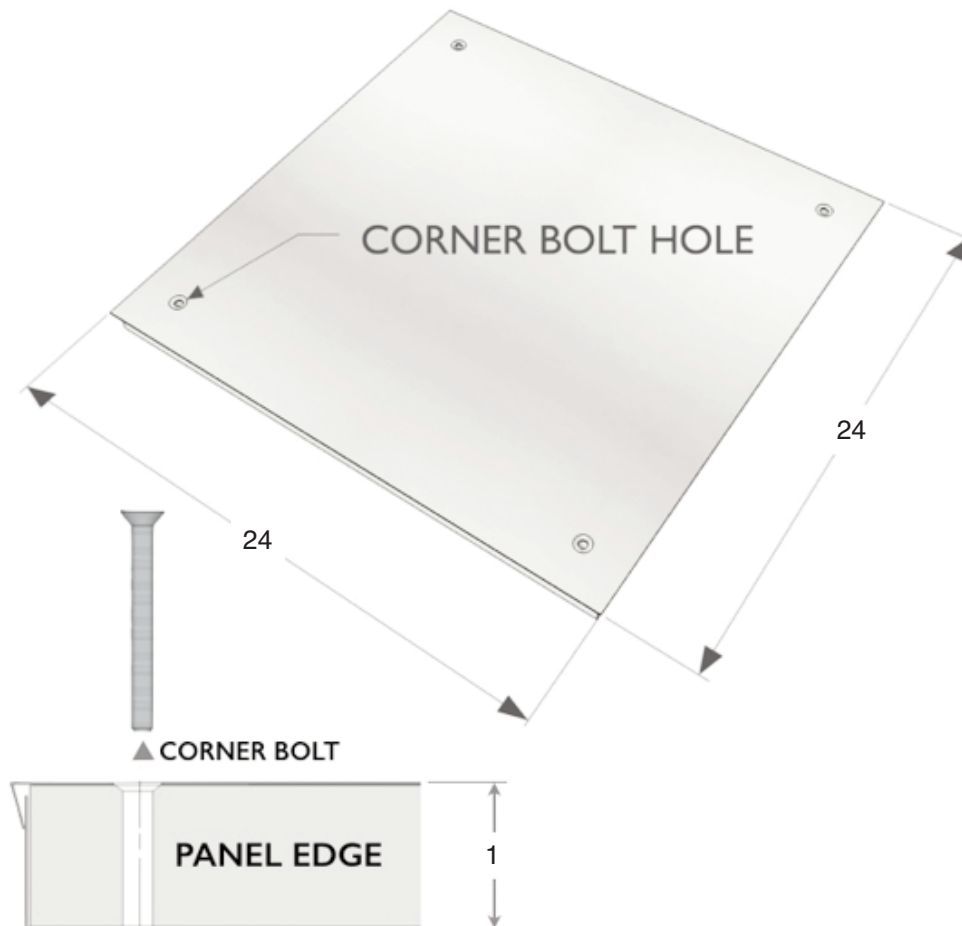

Manufactured by Camino Modular Building Systems

All dimensions are in inches.

JOB NAME:

SUBMITTED BY: