



**PRODUCT FEATURES**

- Solid, underfoot feel and sound
- Bare-corner/bolted stringer & bolted corner assembly options
- Conductive ground path from panel to pedestal
- Sustainable FSC core options available
- Over-sized panels available for perimeter applications

**CONSTRUCTION FEATURES**

- Material:**  
Wood core & galvanized steel composite design
- Finish:**
- Carpet Tile
  - High Pressure Laminate
  - Conductive / Dissipative Vinyl
  - Other : \_\_\_\_\_

**MODELS**

- WC1000-BCL** Design Load 1000 lbs.
- WC1000-BCL-C** Design Load 1000 lbs.  
*CISCA Rated*
- WC1250-BCL** Design Load 1250 lbs.
- WC1250-BCL-C** Design Load 1250 lbs.  
*CISCA Rated*
- WC1500-BCL** Design Load 1500 lbs.
- WC1500-BCL-C** Design Load 1500 lbs.  
*CISCA Rated*

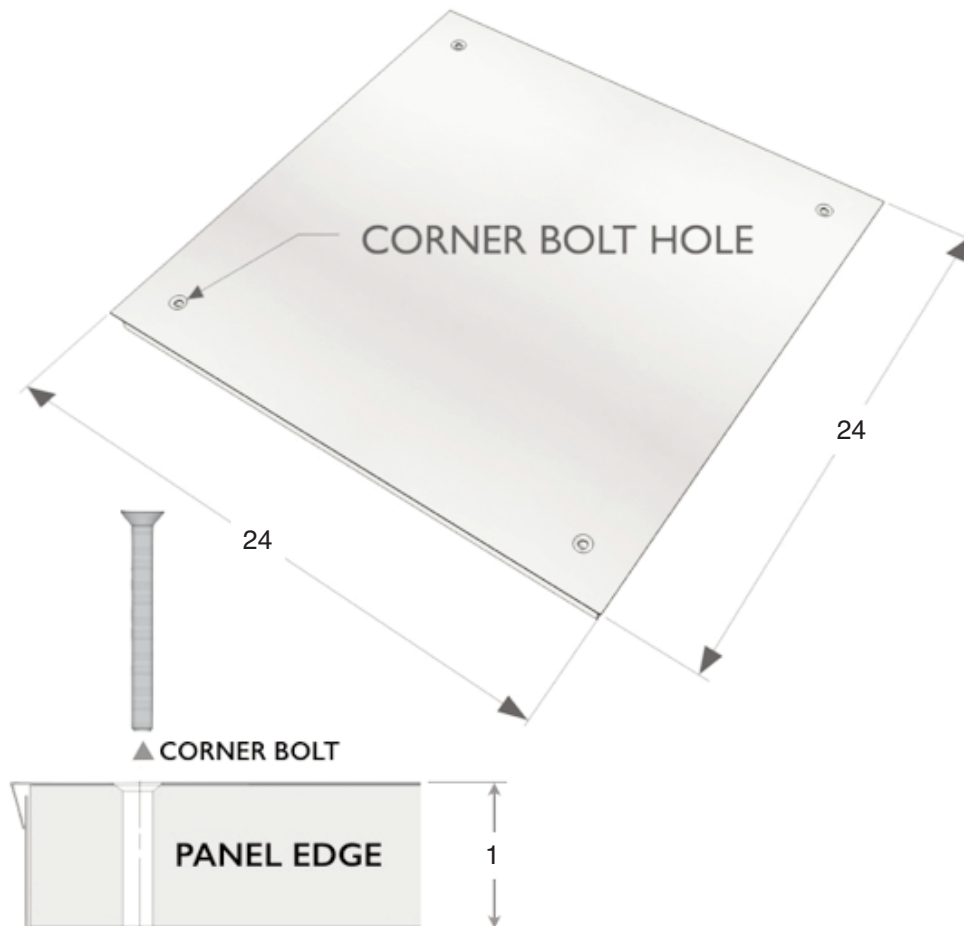

Manufactured by Camino Modular Building Systems

All dimensions are in inches.

**JOB NAME:**

**SUBMITTED BY:**