

- Manual Ball Valve
- Measurflo Fixed Auto Flow Control
- .50 - 5.0 GPM
- Sizes 1/4", 3/8", 1/2", 3/4"

PRODUCT FEATURES

- FNPT, FSWT and MNPT Outlet / Inlet Connections
- Changeable GPM Flow Cartridges
- Flow Rates Available: 0.5 , .75, 1.0, 1.5, 1.75, 2.0, 2.5, 3.0, 3.5, 4.0, 4.5, 5.0
- Differential Operating Pressure:
2-80 PSID 0.50-3.00 GPM
3-80 PSID 3.50-5.00 GPM
- ± 10% Accuracy
- Operating Temperature Range 32°F to 225° F
- 1/4" Pressure / Temperature Ports
- Inlet and Outlet Port Options
- Short Handle (Shown)
- Valves Labeled with Model No., Size & Flow Rate
- Dryseal Pipe Threads
- Weighs between 1.2 - 1.5 lbs.
- Suitable for 600 PSIG

OPTIONS

- Plugged (Ports Machined w/1/4" Plug)
- Pressure Taps
- Extended Handles
- Extended Pressure / Temperature Ports
- Stainless Steel Tag-Chain Upon Request

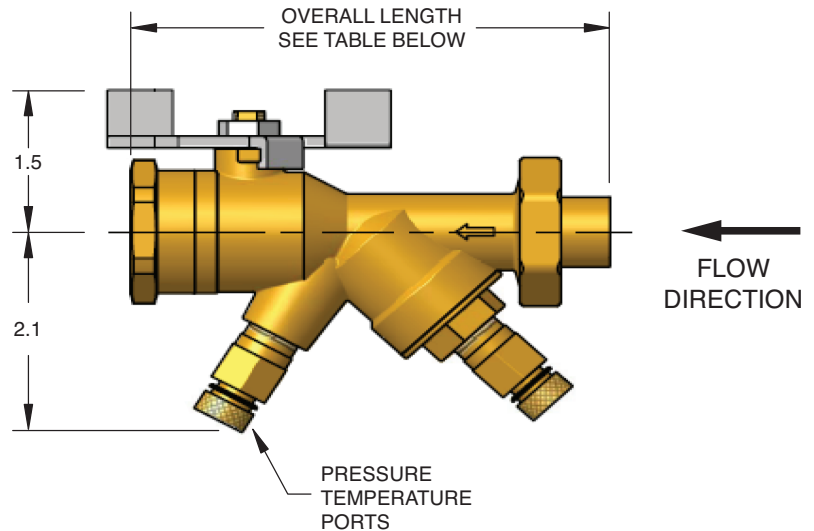

OVERALL LENGTH (All length calculations are machined union end fittings)								
Outlet	1/4" FSWT	3/8" FSWT	1/2" FNPT	1/2" MNPT	1/2" FSWT	3/4" FNPT	3/4" MNPT	3/4" FSWT
Inlet								
1/4" FSWT	4.5	4.5	5.2	5.1	4.5	4.8	5.2	4.5
3/8" FSWT	4.5	4.5	5.2	5.1	4.5	4.8	5.2	4.5
1/2" FNPT	4.6	4.6	5.2	5.1	4.6	4.8	5.2	4.6
1/2" MNPT	5	5	5.7	5.5	5.0	5.2	5.6	5.0
1/2" FSWT	4.5	4.5	5.2	5.1	4.5	4.8	5.2	4.5
3/4" FNPT	4.9	4.9	5.6	5.5	4.9	5.1	5.6	4.9
3/4" MNPT	5	5	5.7	5.6	5.0	5.3	5.7	5.0
3/4" FSWT	4.7	4.7	5.4	5.3	4.7	4.9	5.4	4.7

MATERIAL SPECIFICATIONS	
Valve Body	Brass
Short Handle (Standard)	Zinc Plated Steel
Ball	Chrome Plated Brass
Pressure / Temperature Ports	Brass
O-Rings	EPDM
Ball Seat	Teflon
Stem	Brass
End Cap	Brass
Diaphragm	EPDM
Ball Valve End Fitting	Brass
Orifice	Polyphenylsulfone

Manufactured by Hays Fluid Controls

All dimensions are in inches.

JOB NAME:

SUBMITTED BY: