

Model **2513**

- Mesurflo Fixed Auto Flow Control
- Changeable Flow Cartridge (In-Line)
- .50 – 9.0 GPM
- Sizes 1/2" 3/4", 1"

Standard Features:

- 1/2", 3/4" & 1" FSWT Inlet / Outlet Connections
- 3/4" Female & Male Garden Hose Inlet / Outlet Connections
- 1/2" & 3/4" FNPT & MNPT Inlet / Outlet Connections
- Changeable GPM Flow Cartridges
- Differential Operating Pressure:
2-80 PSID 0.50-5.00 GPM
3-80 PSID 5.50-9.00 GPM
- ± 10% Accuracy
- Operating Temperature Range
32°F to 225° F
- Dryseal Pipe Threads
- Valves Labeled with Model No., Size & Flow Rate
- Valve Body Suitable for 600 PSIG

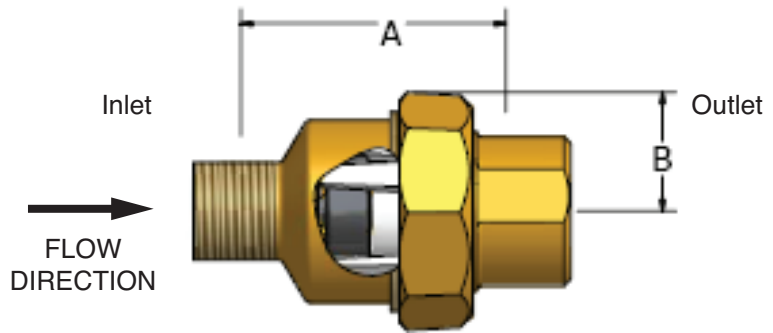

Dimensions			
A		B	
IN	MM	IN	MM
1.9	48	1.25	32

MATERIAL SPECIFICATIONS	
Valve Body	Brass
Tailpiece	Brass
Coupling Nut	Brass
O-Rings	EPDM
Diaphragm	EPDM
Orifice	Polyphenylsulfone

Manufactured by Hays Fluid Controls

All dimensions are in inches.

JOB NAME:

SUBMITTED BY: