

Model **2528**

- Ball Valve for use with Pop-Top Actuators
- Mesurflo Fixed Auto Flow Control
- Changeable Flow Cartridge (Y-Body)
- .50 – 5.0 GPM
- Sizes 1/2", 3/4"

Standard Features:

- FNPT, FSWT, MSWT and MNPT Outlet / Inlet Connections
- Changeable GPM Flow Cartridges
- Differential Operating Pressure: ¹ (See Footnote Below)
- ± 10% Accuracy
- Operating Temperature Range 32°F to 225° F
- 1/4" Pressure / Temperature Ports
- Valves Labeled with Model No., Size & Flow Rate
- Inlet and Outlet Port Options
- Dryseal Pipe Threads
- Weighs between 1.2 - 1.5 lbs. without the actuator^a
- Valve Body Suitable for 600 PSIG
- Cycle Life of Ball Valve Greater than 100,000 Full Cycles
- Torque Less Than 10 in. lbs. @300 PSID

Options:

- Plugged (Ports Machined w/1/4" Plug)
- Pressure Taps
- Extended Pressure / Temperature Ports
- Stainless Steel Tag-Chain Upon Request

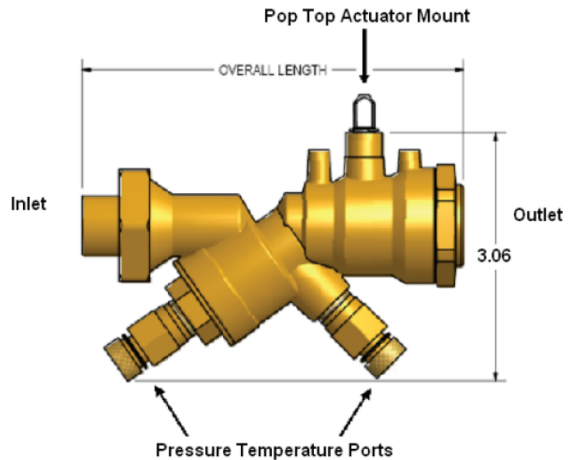
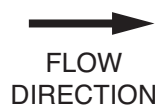

OVERALL LENGTH						
Outlet	1/2" FNPT	3/4" MNPT	1/2" MNPT	3/4" MNPT	1/2" FSWT	3/4" FSWT
Inlet						
1/2" FNPT	5.2	4.8	5.1	5.2	4.6	4.6
3/4" FNPT	5.6	5.1	5.5	5.6	4.9	4.9
1/2" MNPT	5.7	5.2	5.5	5.6	5.0	5.0
3/4" MNPT	5.7	5.3	5.6	5.7	5.0	5.0
1/2" FSWT	5.2	4.8	5.1	5.2	4.5	4.5
3/4" FSWT	5.4	4.9	5.3	5.4	4.7	4.7

^aRefer to Components Section for specifications on ATC6, ATC7, and ATC8.

MATERIAL SPECIFICATIONS

Valve Body	Brass
Union End	Brass
Ball	StainlessSteel
Pressure/ Temperature Ports	Brass
O-Rings	EPDM
Ball Seat	PTFE
Stem	StainlessSteel
End Cap	Brass
Diaphragm	EPDM
Ball Valve End Fitting	Brass
Orifice	Polyphenylsulfone

¹At low differential pressure the flow area required to achieve higher flow exceeds the flow area available for the respective Series. Therefore, the minimum pressure differential requirement is increased for the higher flow ranges of some series Mesurflo valves.

Manufactured by Hays Fluid Controls

All dimensions are in inches.

JOB NAME:

SUBMITTED BY: