



Anemostat®

SUBMITTAL

A MESTEK COMPANY

1220 Watson Center Road • Carson, CA 90745-4206
 (310) 835-7500 • FAX (310) 835-0448
 air@anemostat.com • www.anemostat.com

Model **XS800-3**
HIGH CAPACITY SUPPLY DIFFUSER
 3-3/4" HIGH
 PERFORATED

DIFFUSERS

PRODUCT FEATURES

- 2-Way Horizontal Discharge Pattern
- High Capacity Design
- Beveled Outer Frame
- Perforated Face 51% Free Area

CONSTRUCTION DETAILS

Material:

- Cold Rolled Steel
- Aluminum
- 304 Stainless Steel
- 316 Stainless Steel

Finish:

- White Epoxy
- Satin Polish (Stn Steel Only)
- Custom Colors

MODELS

- XS800-3** 3-3/4" High

ACCESSORIES

- OB-1** Volume Damper

FULL SECTIONS NOM LENGTH L
24"
36"
48"
60"
72"

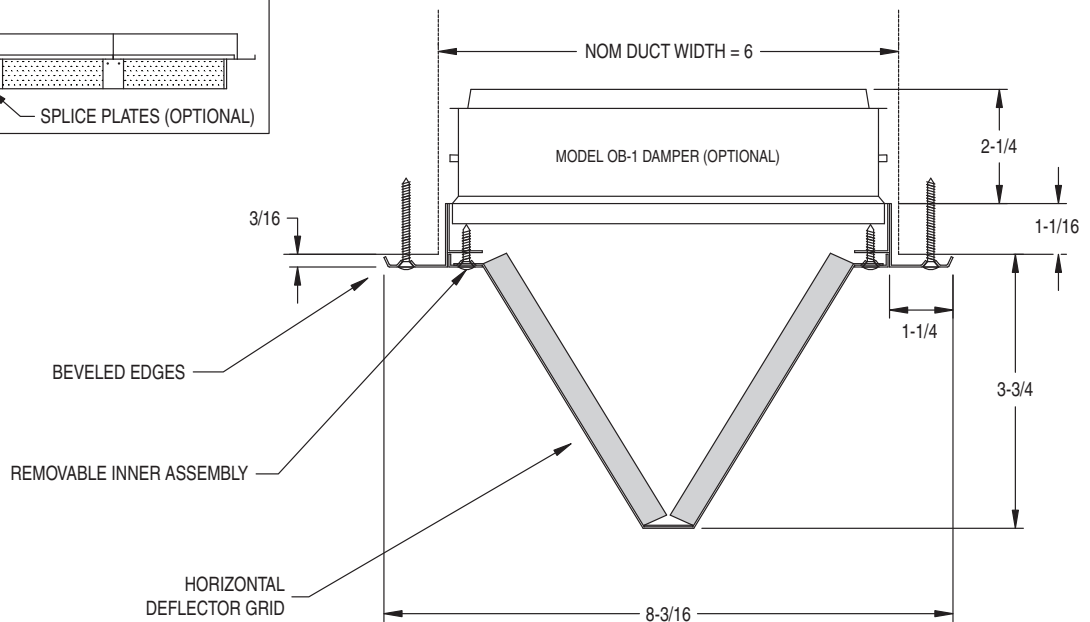
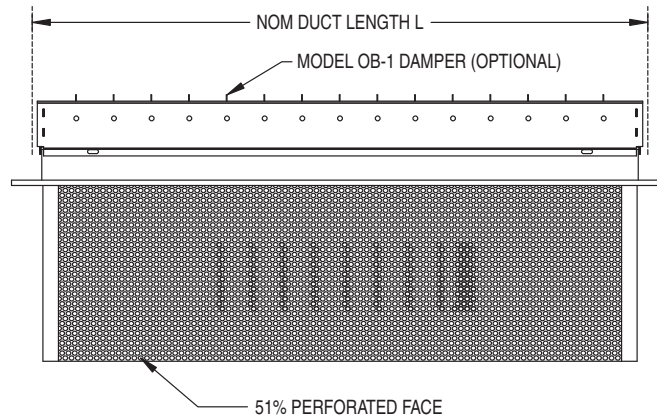
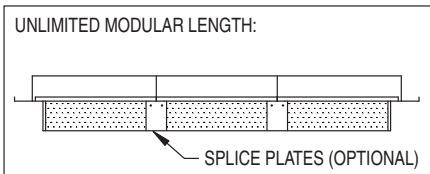

All dimensions are in inches.

JOB NAME:

SUBMITTED BY: