

APPLICATION

- Where rugged construction and high performance is required in industrial plants, paper & textile mills, food processing facilities, etc
- Versatile double deflection air pattern control for throw and spread
- Excellent for general ventilation, and spot heating and cooling
- Worker adjustability for personal control of air direction and pattern

PRODUCT FEATURES

- Double deflection grilles to direct air precisely where needed
- Heavy, all extruded aluminum, corrosion resistant construction for industrial environments
- 1-1/2" long, double barrel blades withstand abuse
- 1-1/2" blade spacing handles large air volumes with minimal pressure loss while minimizing collection of contaminants such as lint, dust, and or particulates
- Registers include a factory attached, steel opposed blade volume control damper
- Mounting holes in frame neatly countersunk for supplied #8 x 1-1/2" oval head screws
- Arctic white baked-on finish
- Maximum size one piece construction is 48" x 48". Model IS over 24" high has second bank of blades split into two sections with two handles and two movement bars. Larger sizes shipped in multiple pieces for field assembly

GRILLE OPTIONS

- Model IS/S includes gang operated rear blades for pole operation. Optional sash chain and pulley available upon request. Front blades are always vertical.
- Factory applied gasket material to frame
- Aluminum opposed blade volume control dampers
- Custom or optional paint colors

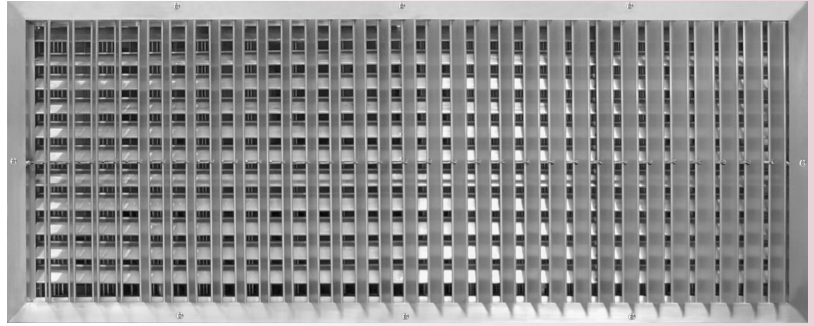

Model XW/S

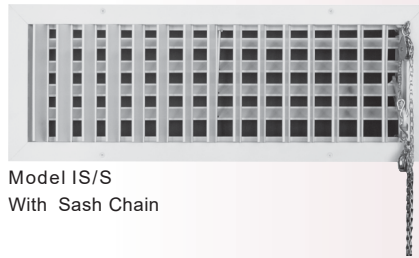

Model IS/S
With Sash Chain

| | |
|---|---|
| <ul style="list-style-type: none"> • Model XW/S Double deflection grille, front blades short, 1-1/2" spacing, blades are independently adjustable | <ul style="list-style-type: none"> • Model IS/S Double deflection grille, front blades short, 1-1/2" spacing, gang operated horizontal rear blades are pole operated by moving heavy 3/16" x 1" lever (pole not included) |
| <ul style="list-style-type: none"> • Model XW/L Double deflection grille, front blades long, 1-1/2" spacing, blades are independently adjustable | <ul style="list-style-type: none"> • Model IS/S w/ Sash Chain Double deflection grille, front blades short, 1-1/2" spacing, gang operated horizontal rear blades are adjusted with sash chain and pulley arrangement |

Model XW

Independently Adjustable Blades

XW/S
• Front Blades Short
• Rear Blades Long

XW/L
• Front Blades Long
• Rear Blades Short

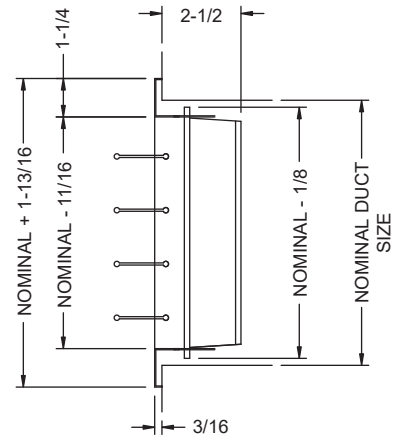
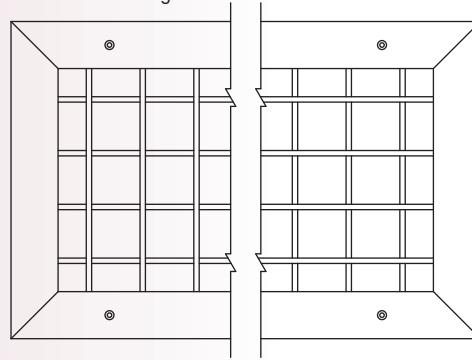

Model IS

Pole Operated Rear Blades

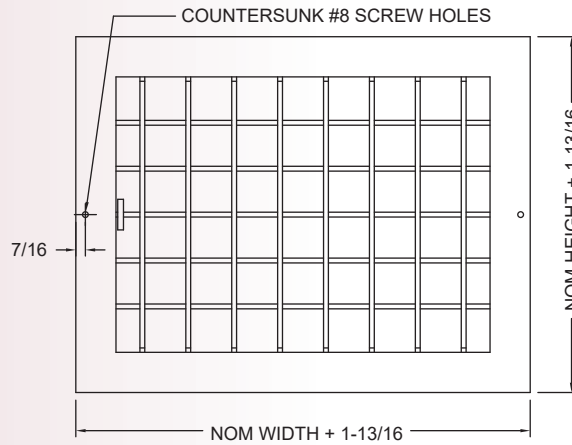

IS/S
• Front Blades Short
• Rear Blades Long
• Optional Opposed Blade Damper

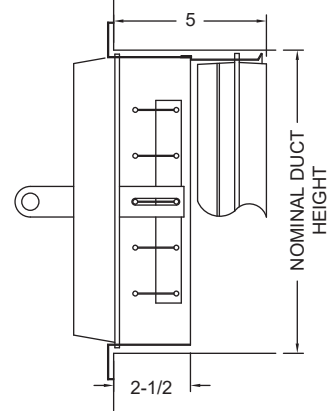

Model IS

Chain Operated Rear Blades

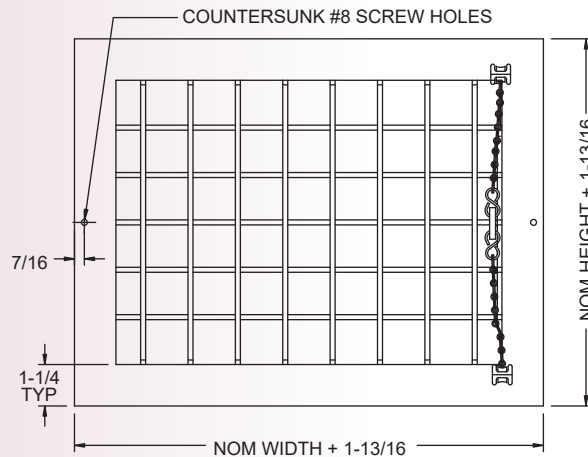

IS/S with Sash Chain
• Front Blades Short
• Rear Blades Long
• Optional Opposed Blade Damper

