

## INTEGRATED PLENUM with "RAPITACH" MOUNTING PLATE

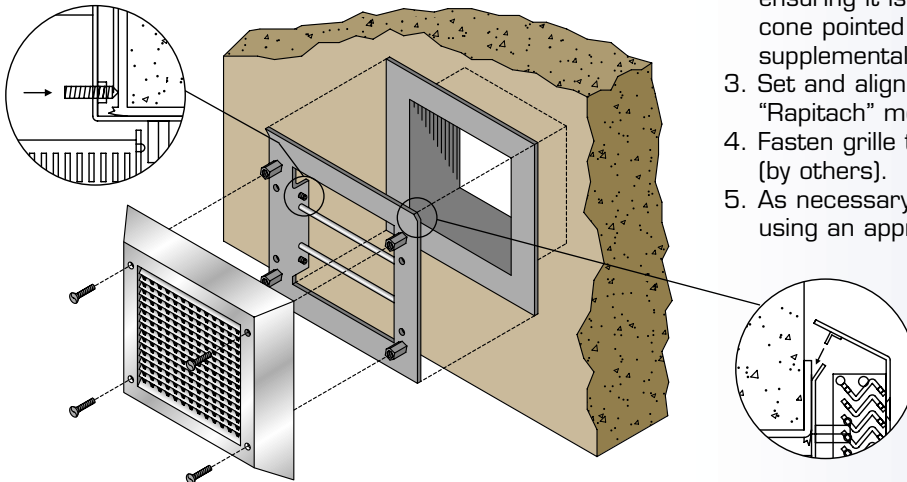

## S-VENT® MODELS SSV22, SSV23, SSV26 and SSV42

1. Cut out the existing grille face, while leaving the face flange and sleeve in place.
2. Insert "Rapitach" mounting plate into existing grille ensuring it is properly orientated and secure with the cone pointed setscrews supplied. Holes supplied for supplemental welded attachments.
3. Set and align the grille (with integrated plenum) to the "Rapitach" mounting plate.
4. Fasten grille to plate using approved security screws (by others).
5. As necessary, seal any gaps around the faceplate using an approved security sealant.

## INTEGRATED PLENUM with FACE MOUNTED GRILLE

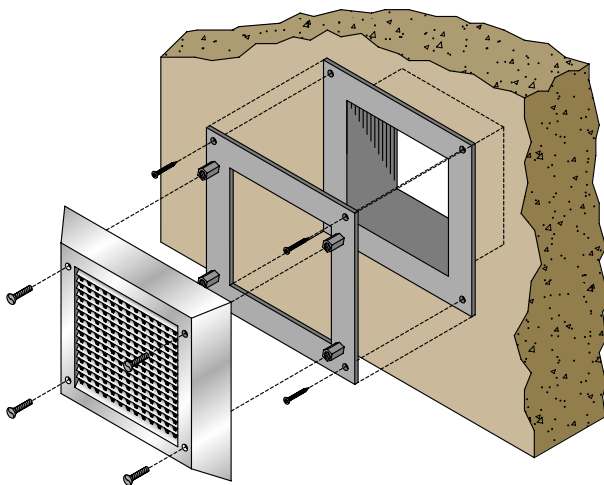

## S-VENT® MODELS SSV22, SSV23, SSV26 and SSV42

1. For more efficient air flow, cut out the existing grille face. Leave all else in place.
2. Attach the mounting plate using screws (by others) or by welding.
3. Fasten grille to plate using approved security screws (by others).
4. As necessary, seal any gaps around the faceplate using an approved security sealant.

## FACE MOUNTED GRILLE and PLATE

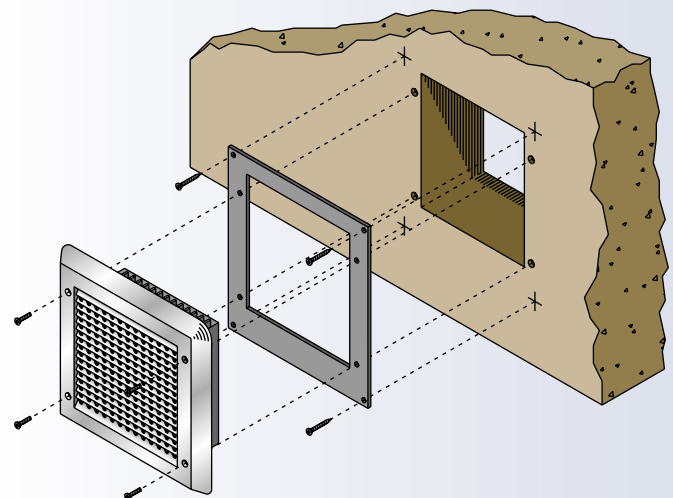

## S-VENT® MODELS SSV22, SSV23, SSV26 and SSV42

1. Attach the mounting plate using screws (by others) or by welding.
2. Fasten grille to plate using approved security screws (by others).
3. As necessary, seal any gaps around the faceplate using an approved security sealant.

United States Patents issued for S-Vent®  
5,375,373 and 6,113,488

**NOTE:** To maximize sealant use, prepare enough plenum rough-ins so that a full tube of caulking can be used.