

ANEMOSTAT[®]

AIR TERMINAL CONTROLS

Control Package
FP - D - D8005A

- PARALLEL FAN AIR TERMINAL
- ELECTRIC HEAT - PROPORTIONAL CONTROL SCR
- HEATER AIR FLOW SWITCH
- SIMPLY VAV DIRECT DIGITAL CONTROLS

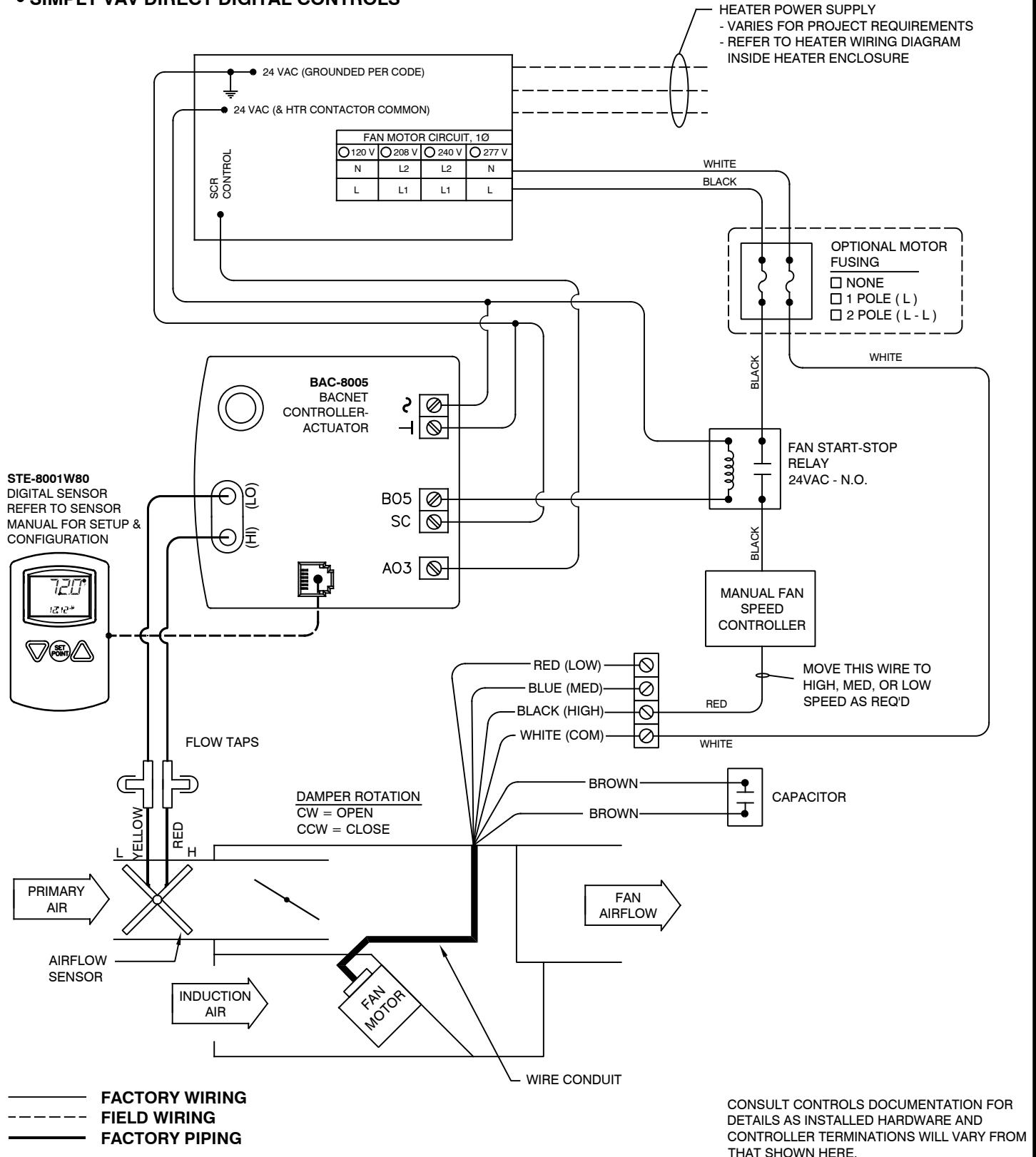

JOB NAME:
SUBMITTED BY:
DATE:

DWG #: FP-D-D8005A
REV: -
DATE: 11-8-2017