

# ANEMOSTAT®

## SINGLE DUCT AIR TERMINAL

# Control Package

## SD - D - 8001D

- BACNET DIGITAL CONTROLS
- VAV COOLING WITH HOT WATER REHEAT (PROP 0-10VDC)
- PRESSURE INDEPENDENT
- SENSOR STE-6010W80

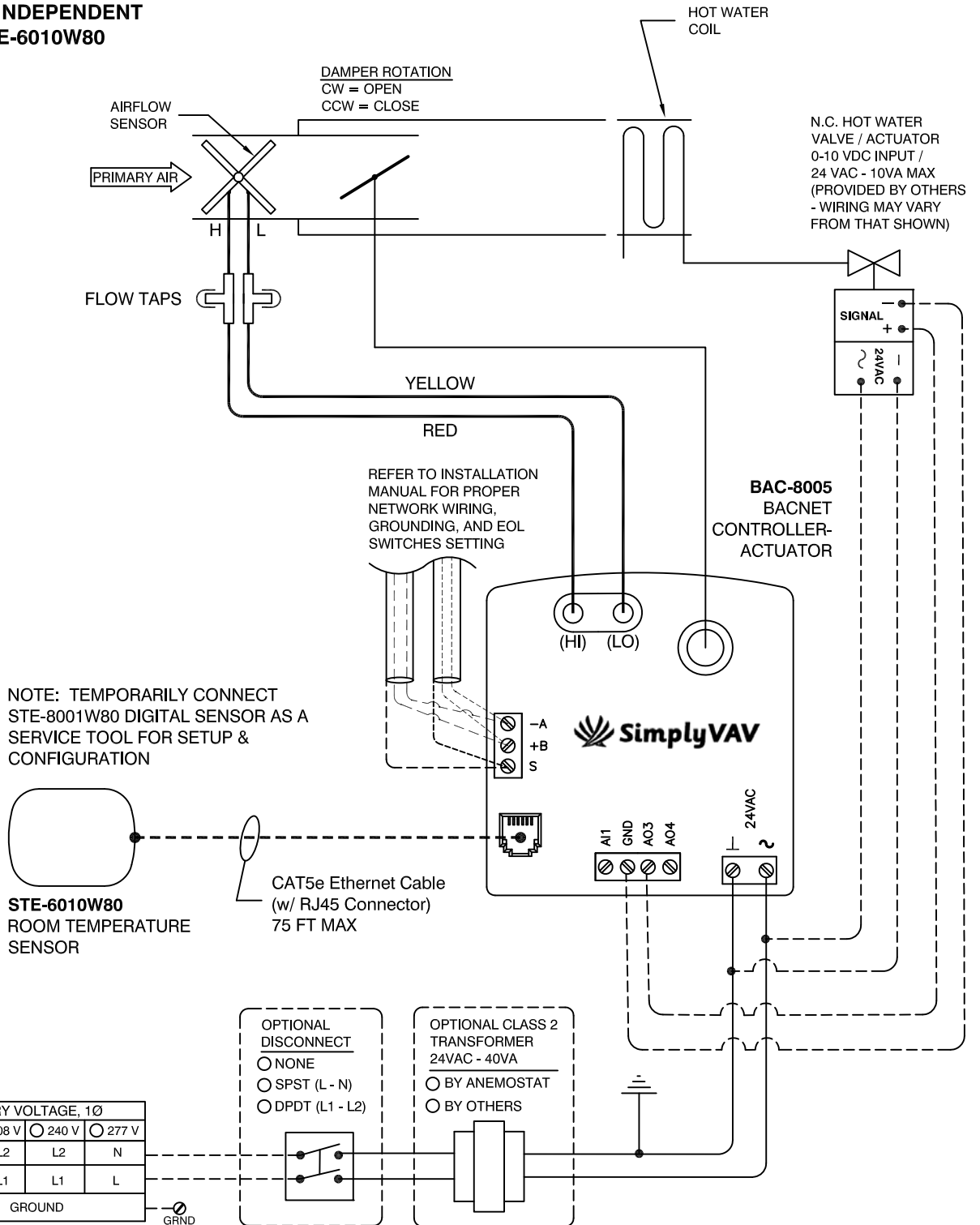

REFER TO ANEMOSTAT "CONTROLS MANUAL" (CM-1) FOR ADJUSTMENT & TROUBLESHOOTING PROCEDURES.

JOB NAME:  
SUBMITTED BY:  
DATE:

DWG #: SD-D-8001D.1  
REV: B  
DATE: 03-01-17