

SUBMITTAL SHEET



Anemostat
A MESTEK COMPANY

P.O. BOX 4938 • 1220 WATSONCENTER ROAD • CARSON, CA 90745-4206
(310) 835-7500 • FAX (310) 835-0448
e-mail: airsec@anemostat.com • website: www.anemostat.com

3RPLD-MS

MINIMUM SECURITY

PERFORATED RETURN
for LOCK DOWN CEILING**
(LAY-IN T-BAR CEILING)

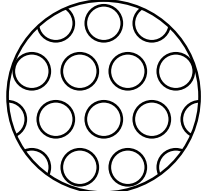
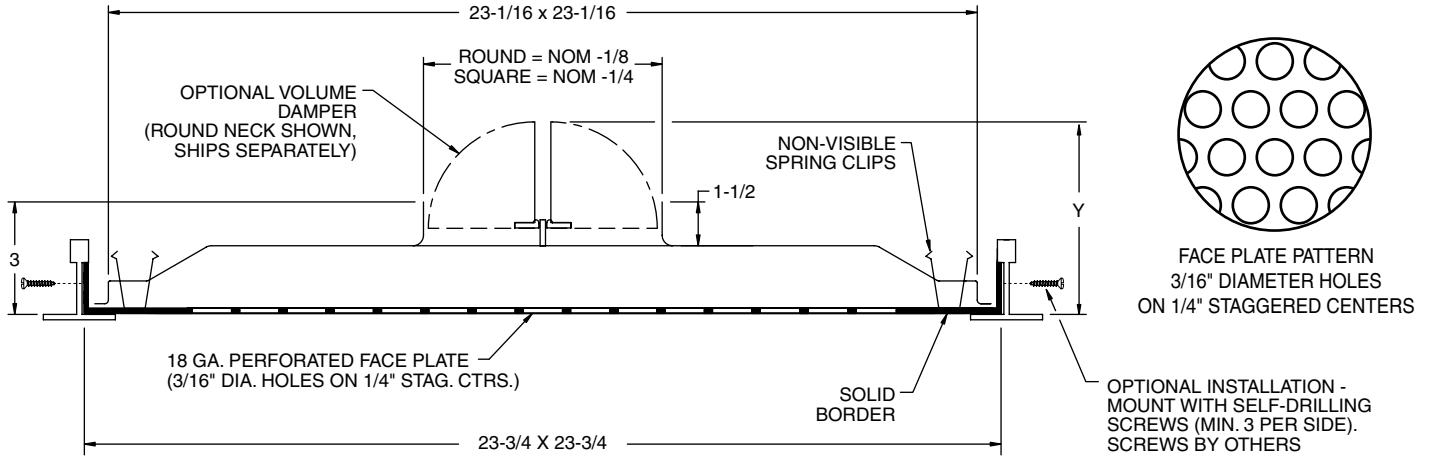

FACE PLATE PATTERN
3/16" DIAMETER HOLES
ON 1/4" STAGGERED CENTERS

OPTIONAL INSTALLATION -
MOUNT WITH SELF-DRILLING
SCREWS (MIN. 3 PER SIDE).
SCREWS BY OTHERS

IMPORTANT: It is the specifier's responsibility to properly configure the HVAC system to meet the appropriate level of comfort, safety, security and detention

PRODUCT FEATURES

Face Plate

- 18 GA. (standard)
- 16 GA. (optional)

Face Plate Patterns

- 3/16" dia. holes on 1/4" stag. ctrs. (std.)
- 1/4" dia. holes on 3/8" stag. ctrs. (opt.)
- 5/16" dia. holes on 7/16" stag. ctrs. (opt.)

Material

- Cold Rolled Steel (standard)
- *Stainless Steel (optional)
- *Aluminum (optional)
- *Galvanized (optional)
- Other _____

*consult factory for availability

Opposed Blade Damper -(optional) (Square Neck)

- Front Operated
- Rear Operated
- Other _____

Butterfly Volume Damper -(optional) (Round Neck)

- Front Operated
- Other _____

Finish

- White Powder Coat (standard)
- Other _____

Other Options (please specify)

QUANTITY										
Round Neck	NOMINAL NECK DIAMETER	6ø	7ø	8ø	9ø	10ø	12ø	14ø	16ø	18ø
	OPTIONAL DAMPER	Y DIMENSION	4-1/2	5	5-1/2	6	6-1/2	7-1/2	8-1/2	9-1/2
QUANTITY										
Square Neck	NOMINAL NECK SIZE	6x6	-	8x8	-	10x10	12x12	14x14	16x16	18x18
	OPTIONAL OBD	Y DIMENSION	5-3/8							

**consult factory with ceiling details to verify compatibility

All dimensions are in inches.

SUBMITTAL APPROVAL

Job Name and Location			
Engineer	Date	Factory	Date
Mfr. Rep.	Date	Submitted By	Date