



Model **AL / TL**  
**ALUMINUM LINEAR**  
**BAR GRILLES**  
BF BORDER  
(PLASTER FRAME)  
WITH 1" FILTER FRAME

# SUBMITTAL SHEET

## PRODUCT FEATURES

- "Plaster in Place" BF frame for high end appearance
- Extruded aluminum construction
- Lengths to 120" for full sections.  
Unlimited length continuous runs (96" max sections) using frame alignment strips
- Alignment hardware shipped loose
- Core construction – see Core Options

## CONSTRUCTION DETAILS

Material: Extruded Aluminum

Finish:

- Arctic White Baked Finish
- Natural Anodize
- Custom Color \_\_\_\_\_

## CORE CONSTRUCTION

See Core Options submittal sheet

## FRAME CONSTRUCTION

Available with Borders 6, 7, or 9

## ACCESSORIES

- OB-ST Opposed Blade Damper (Steel)
- OB-AL Opposed Blade Damper (Alum)

AL1 CORE SHOWN

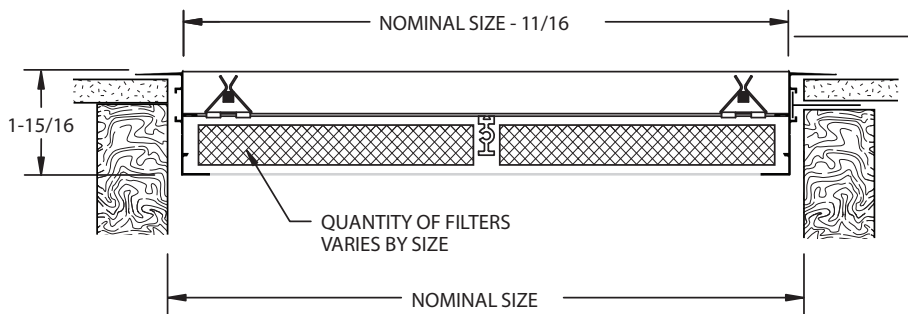
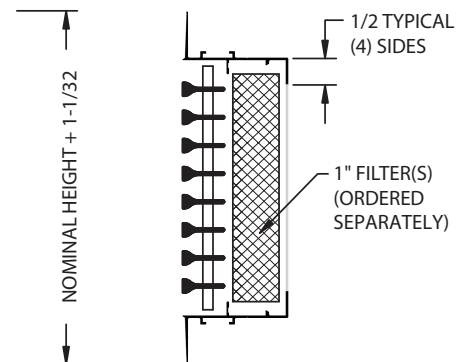
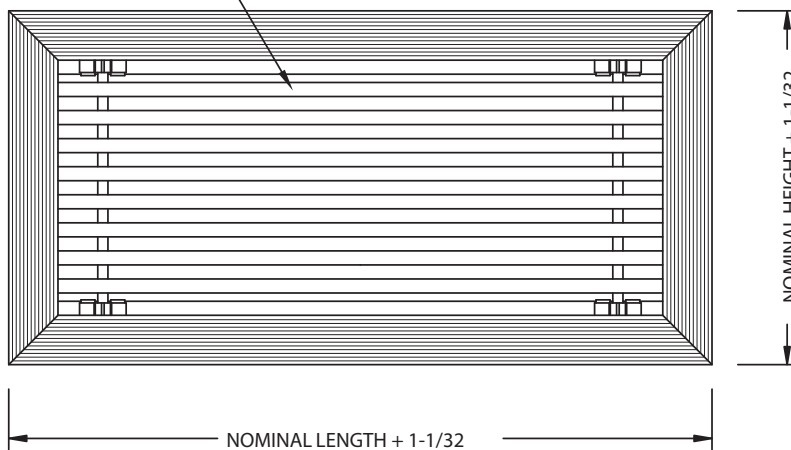

- OPTIONAL MOUNTING TAB FOR USE WITH 5/8" GWB / DRYWALL

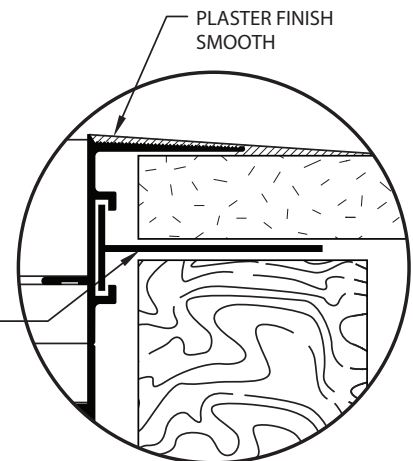

All dimensions are in inches.

JOB NAME:

SUBMITTED BY:

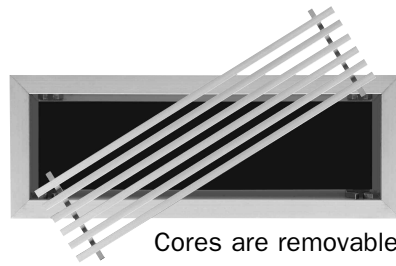

Cores are removable

**PRODUCT FEATURES**

- Extruded aluminum construction
- (7) Cores to choose from for appearance and deflection angle
- Removable core is standard on heights to 18"
- Non-removable core on heights over 18" (welded)
- Double deflection option includes rear louvers (individually adjustable) for spread control

**AL1\***  
SINGLE DEFLECTION

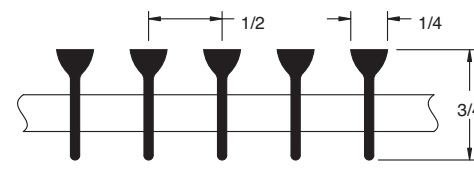

**AL2\***  
DOUBLE DEFLECTION (Spread Control)

**DEFLECTING BAR 0° STANDARD**

---

**AL15\***  
SINGLE DEFLECTION

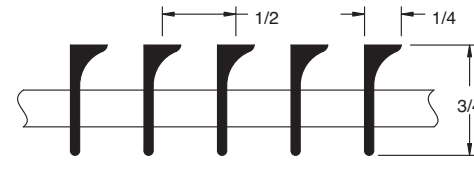

**AL25\***  
DOUBLE DEFLECTION

**DEFLECTING BAR 15° STANDARD**

---

**AL45\***  
SINGLE DEFLECTION

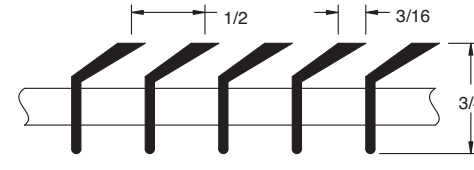

**AL245\***  
DOUBLE DEFLECTION

**DEFLECTING BAR 45° STANDARD**

---



**PENCIL PROOF**

**TL1W**  
SINGLE DEFLECTION

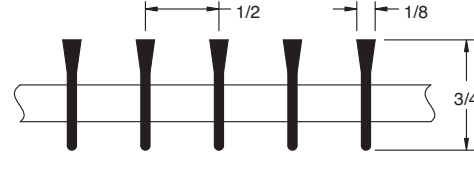

**TL2W**  
DOUBLE DEFLECTION

**DEFLECTING BAR 0° THINLINE**

---

**TL15W**  
SINGLE DEFLECTION

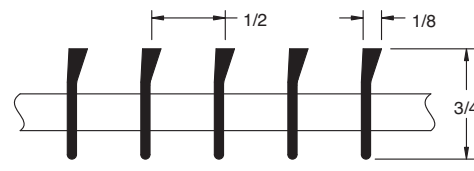

**TL25W**  
DOUBLE DEFLECTION

**DEFLECTING BAR 15° THINLINE**

---

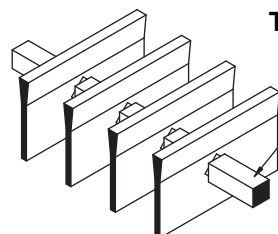

**TYPICAL CORE ASSEMBLY**

Core cross bars are on 10" centers for AL style cores, 5" centers for TL style cores. Cross bars are 5" centers for all cores used with floor reinforcement.

**TL1N\***  
SINGLE DEFLECTION

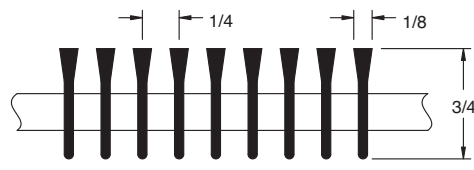

**TL2N\***  
DOUBLE DEFLECTION

**DEFLECTING BAR 0° THINLINE**

---

**TL15N\***  
SINGLE DEFLECTION

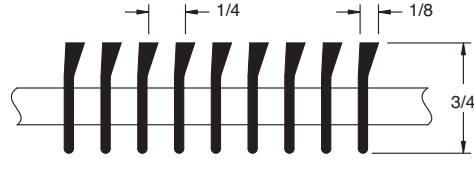

**TL25N\***  
DOUBLE DEFLECTION

**DEFLECTING BAR 15° THINLINE**

---



**PENCIL PROOF**

\*PENCIL PROOF: Models AL1, AL2, AL15, AL25, AL45, AL245, TL1N, TL2N, TL15N, TL25N are pencil proof

All dimensions are in inches.

JOB NAME:

SUBMITTED BY:

# SUBMITTAL SHEET

www.anemostat-hvac.com

- Grille Nominal Size = Grille Order Size
- Refer to dimensions below to convert to nominal order size

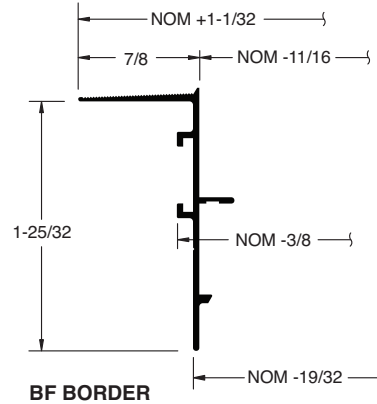
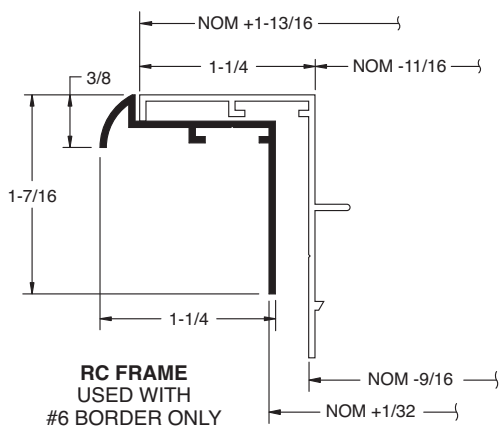
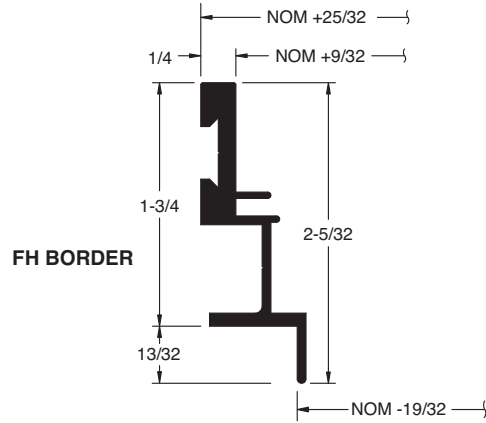
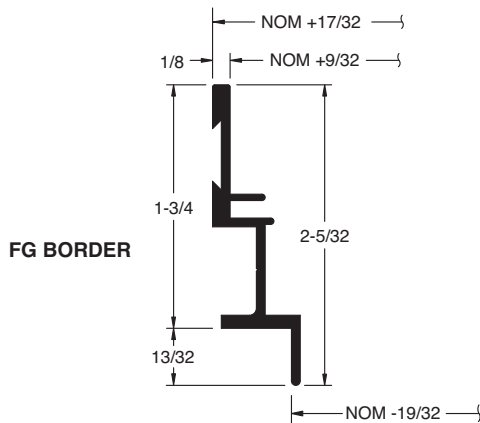
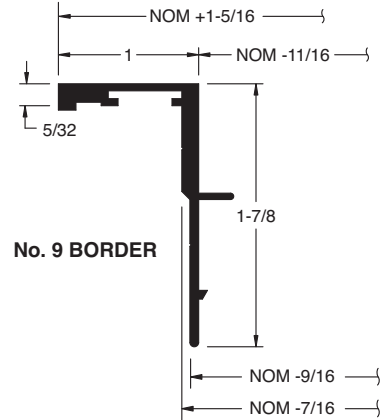
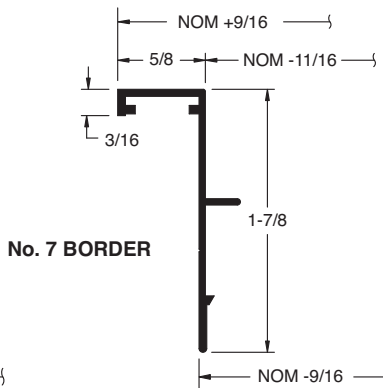
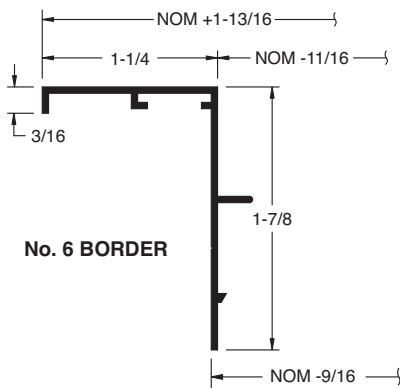

All dimensions are in inches.

JOB NAME:

SUBMITTED BY: