



# Anemostat®

AIR DISTRIBUTION

## SUBMITTAL SHEET

www.anemostat-hvac.com



# SOUND ATTENUATOR

RECTANGULAR  
LOW FREQUENCY  
MOLD RESISTANT  
COTTON FILL

### PRODUCT FEATURES

- **FILL:** Mold resistant cotton under compression
- Tested in accordance with ASTM E-477
- Single piece construction from: 6" x 6" to 48" x 48"
- **ASTM-E84 Rating Characteristics:**  
Flamespread - 5  
Smoke Developed - 35

### CONSTRUCTION FEATURES

- **Casing:**  
22 Gauge Galvanized Steel
- **Baffles:**  
24 Gauge Perforated Galvanized Steel

### MODELS

- ARLUHP** Ultra High Pressure
- ARLHP** High Pressure
- ARLMHP** Medium High Pressure
- ARLMP** Medium Pressure
- ARLMPL** Medium Low Pressure
- ARLLP** Low Pressure
- ARLULP** Ultra Low Pressure

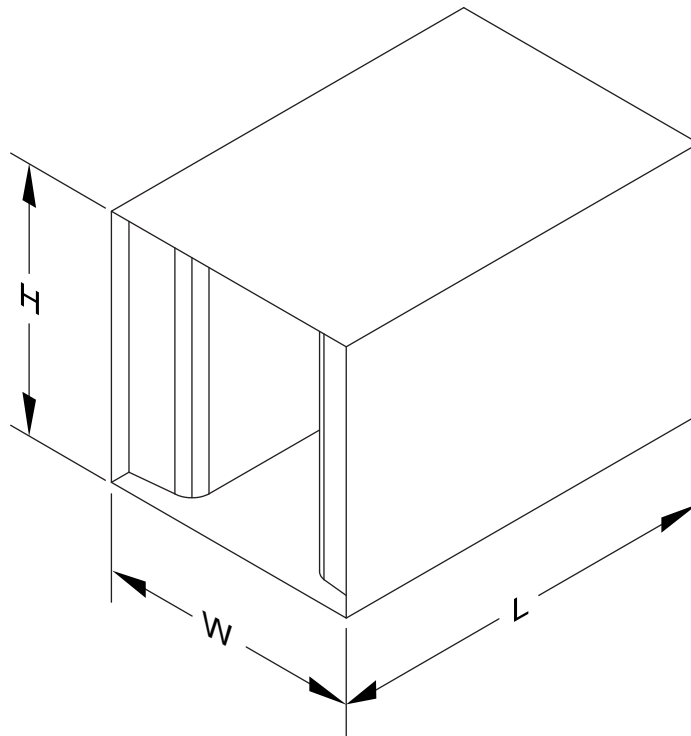

By *AEROSONICS*

All dimensions are in inches.

JOB NAME:

SUBMITTED BY: