

**SINGLE DUCT AIR TERMINAL
w/ INTEGRAL SOUND
ATTENUATOR AND HOT
WATER HEATING COIL**

SUBMITTAL SHEET
www.anemostat-hvac.com

SIZES 05 - 16



PRODUCT FEATURES

- AHRI 880 certified
- Integral sound attenuator reduces discharge sound levels.
- 1, 2, 3, or 4 row hot water coils with 1/2" o.d. copper tubes thru aluminum corrugated fins @10 per inch.
- 22 gauge zinc-coated steel, low leakage casing construction sealed to limit leakage to <1% of max rated flow at 3" w.g. static pressure.
Optional: 20 gauge construction Ultra Lo-Leak construction
- 1/2" dual density insulation (NFPA 90A, UL 181).
Optional: 1" dual density glass fiber insulation
 1/2" 1" foil faced glass fiber insulation – metal taped edges (ASTM C665)
 3/8" ber free closed cell foam insulation (NFPA255, UL181)
 1/2" 1" dual wall construction
 Lo-Temp casing construction
 1" Fibre-Lok : High density foil-faced duct board with steel encapsulated edges (ASTM C665)
 No insulation
- 90° inlet damper with leak resistant perimeter seal limiting leakage to <1% of max rated flow at 3" w.g. inlet static pressure.
- Multi-Point center averaging Velocity Wing air flow sensor for accuracy to ± 5% of design flow. Optional Flow Taps/ Tees
- Slip & drive cleat discharge connection.
- Choice of right hand or left hand control position.
- Optional Accessories:
 6 x 6 Access Plate 6 x 6 Access Door Bottom Side¹
 Hinged Double Camlock
 Unit mounting brackets (field installed)
 Standard control enclosure Large control enclosure
 Screw attached cover Hinged cover
- Control System : Digital Electronic Analog Pneumatic Electric
 None – No controls By ATC - Factory Installed
 By Anemostat By ATC - Field Installed

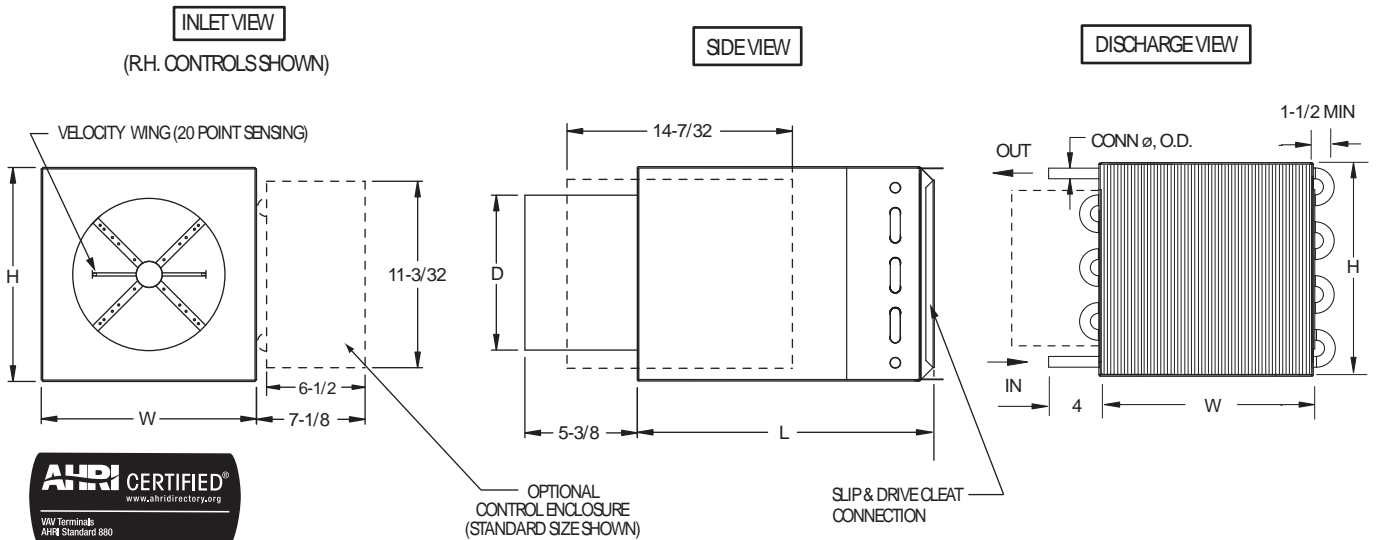

All dimensions are in inches.

Unit Size	Airflow Range, CFM	Inlet Dia D	W	H	1 Row Coil			2 Row Coil			3 Row Coil			4 Row Coil		
					L	Conn ø, O.D.	Approx Weight	L	Conn ø, O.D.	Approx Weight	L	Conn ø, O.D.	Approx Weight	L	Conn ø, O.D.	Approx Weight
05	0 - 290	4-7/8	10	10	42-5/8	1/2	36	43-11/16	1/2	38	44-3/4	7/8	41	46-5/16	7/8	44
06	0 - 470	5-7/8	10	10	42-5/8	1/2	36	43-11/16	1/2	38	44-3/4	7/8	41	46-5/16	7/8	44
07	0 - 615	6-7/8	12	10	42-5/8	1/2	38	43-11/16	1/2	41	44-3/4	7/8	45	46-5/16	7/8	48
08	0 - 870	7-7/8	12	10	42-5/8	1/2	38	43-11/16	1/2	41	44-3/4	7/8	45	46-5/16	7/8	48
09	0 - 1100	8-7/8	14	12-1/2	42-5/8	1/2	51	43-11/16	1/2	54	44-3/4	7/8	60	46-5/16	7/8	65
10	0 - 1355	9-7/8	14	12-1/2	42-5/8	1/2	51	43-11/16	1/2	54	44-3/4	7/8	60	46-5/16	7/8	65
12	0 - 1800	11-7/8	16	15	42-5/8	7/8	58	43-11/16	1/2	62	44-3/4	7/8	69	46-5/16	7/8	76
14	0 - 2470	13-7/8	20	17-1/2	42-5/8	7/8	70	43-11/16	7/8	77	44-3/4	7/8	85	45-13/16	7/8	94
16	0 - 3370	15-7/8	24	17-1/2	42-5/8	7/8	80	43-11/16	7/8	88	44-3/4	7/8	98	45-13/16	7/8	109

NOTES:

1. SIDE ACCESS DOOR STANDARD LOCATION IS ON THE SAME SIDE AS THE CONTROL SIDE.
2. AIRFLOW RANGE SHOWN IS FOR SENSOR dP = 1.00". CONSULT VAV CONTROLLER SPECIFICATIONS FOR ACTUAL MIN AND MAX dP LIMITS.
3. WEIGHT SHOWN IS TOTAL ASSEMBLY WET WEIGHT IN LBS (8.3 LBS/ GALLON)
4. OPTIONAL CONTROL ENCLOSURE LOCATION WILL VARY BASED ON CONTROLS INSTALLED.

JOB NAME:

SUBMITTED BY:



**SINGLE DUCT AIR TERMINAL
w/ INTEGRAL SOUND
ATTENUATOR AND HOT
WATER HEATING COIL
SIZE 24 X 16**

SUBMITTAL SHEET

www.anemostat-hvac.com

PRODUCT FEATURES

- AHRI 880 certified
- Integral sound attenuator reduces discharge sound levels.
- 20 gauge zinc-coated steel, low leakage casing construction sealed to limit leakage to <1% of max rated flow at 3" w.g. static pressure.
- Optional: Ultra Lo-Leak construction
- 1/2" dual density insulation (NFPA 90A, UL 181).
- Optional: 1" dual density glass fiber insulation
 - 1/2" 1" foil faced glass fiber insulation – metal taped edges (ASTM C665)
 - 3/8" fiber free closed cell foam insulation (NFPA255, UL181)
 - 1/2" 1" dual wall construction
 - Lo-Temp casing construction
 - 1" Fibre-Lok : High density foil-faced duct board with steel encapsulated edges (ASTM C665)
 - No insulation
- 1, 2, 3, or 4 row hot water coils with 1/2" o.d. copper tubes thru aluminum corrugated fins @ 10 per inch.
 - 90° multi-blade inlet damper with leak resistant perimeter and jamb seals limiting leakage to <1% of max rated flow @ 3" w.g. inlet static pressure.
 - Multi-Point center averaging Velocity Wing air flow sensor for accuracy to ± 5% of design flow. Optional Flow Taps / Tees
 - Slip & drive cleat discharge connection.
 - Choice of right hand or left hand control position.
 - Optional Accessories:
 - 6 x 6 Access Plate 6 x 6 Access Door Bottom Side
 - Hinged Double Camlock
 - Unit mounting brackets (field installed)
 - Standard control enclosure Large control enclosure
 - Screw attached cover Hinged cover
 - Control System : Digital Electronic Analog Pneumatic Electric
 - None – No controls By ATC - Factory Installed
 - By Anemostat By ATC - Field Installed

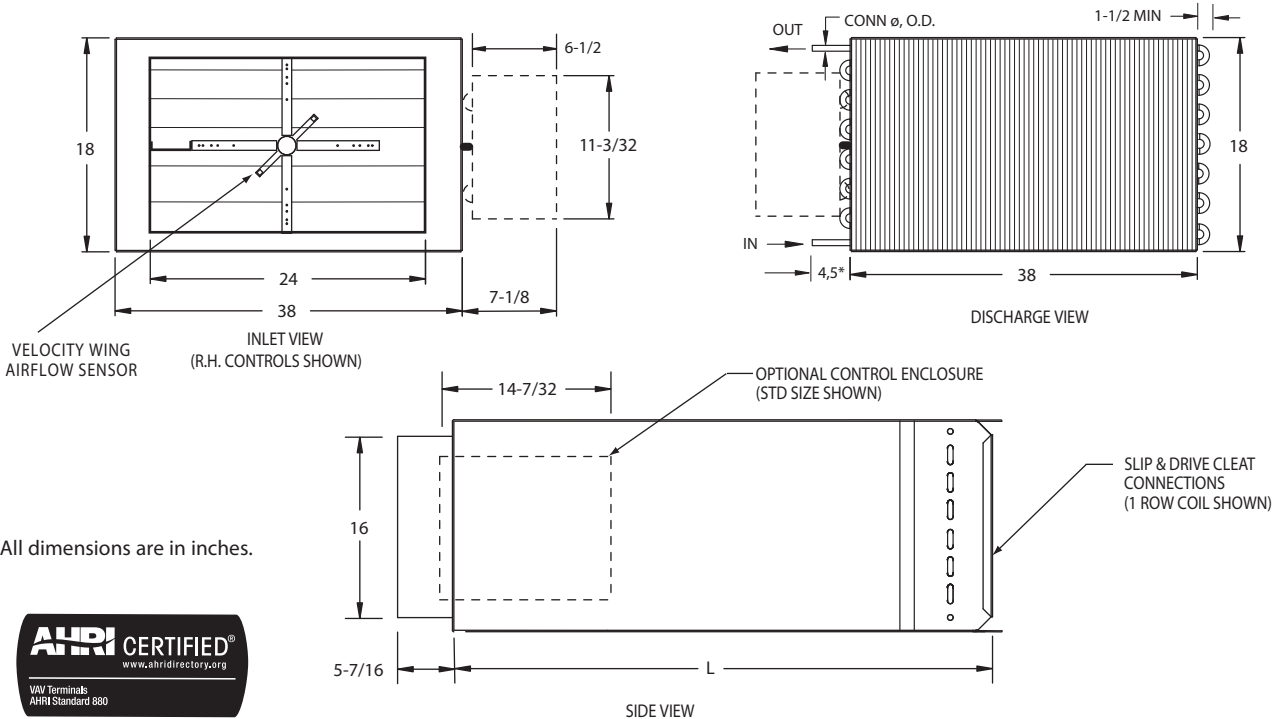

All dimensions are in inches.



Unit Size	Airflow Range, CFM	1 Row Coil			2 Row Coil			3 Row Coil			4 Row Coil		
		L	Conn ø, O.D.	Approx Weight	L	Conn ø, O.D.	Approx Weight	L	Conn ø, O.D.	Approx Weight	L	Conn ø, O.D.	Approx Weight
24x16	0 - 6360	44-1/2	7/8	133	44-1/2	7/8	145	45-1/2	1-1/8	162	45-1/2	1-1/8	178

- NOTES:
- AIRFLOW RANGE SHOWN IS FOR SENSOR dP = 1.00". CONSULT VAV CONTROLLER SPECIFICATIONS FOR ACTUAL MIN AND MAX dP LIMITS.
 - WEIGHT SHOWN IS TOTAL ASSEMBLY WET WEIGHT IN LBS (8.3 LBS / GALLON)
 - OPTIONAL CONTROL ENCLOSURE LOCATION WILL VARY BASED ON CONTROLS INSTALLED.
 - HEADER DIMENSION FROM SIDE OF COIL IS 4" FOR 1, 2 ROW, AND 5" FOR 3, 4 ROW COILS.

JOB NAME: _____ SUBMITTED BY: _____