

BOTTOM CONTROLS

SUBMITTAL SHEET

www.anemostat-hvac.com

PRODUCT FEATURES

- AHRI 880 certified
- 1, 2, 3, or 4 row hot water coils with 1/2" o.d. copper tubes thru aluminum corrugated fins @ 10 per inch. Right or Left Hand coil connections.
- 22 gauge zinc-coated steel, low leakage casing construction sealed to limit leakage to <1% of max rated flow at 3" w.g. static pressure.
 Optional: 20 gauge construction Ultra Lo-Leak construction
- 1/2" dual density insulation (NFPA 90A, UL 181).
 Optional: 1" dual density glass fiber insulation
 1/2" 1" foil faced glass fiber insulation – metal taped edges (ASTM C665)
 3/8" fiber free closed cell foam insulation (NFPA255, UL181)
 1/2" 1" dual wall construction
 Lo-Temp casing construction
 1" Fibre-Lok : High density foil-faced duct board with steel encapsulated edges (ASTM C665)
 No insulation
- 90° inlet damper with leak resistant perimeter seal limiting leakage to <1% of max rated flow at 3" w.g. inlet static pressure.
- Multi-Point center averaging Velocity Wing air flow sensor for accuracy to ± 5% of design flow. Optional Flow Taps / Tees
- Slip & drive cleat discharge connection.
- Optional Accessories:
 6 x 6 Access Plate 6 x 6 Access Door Side ¹
 Hinged Double Camlock
 Unit mounting brackets (field installed)
 Standard control enclosure Large control enclosure
 Screw attached cover Hinged cover
- Control System : Digital Electronic Analog Pneumatic Electric
 None – No controls By ATC - Factory Installed
 By Anemostat By ATC - Field Installed

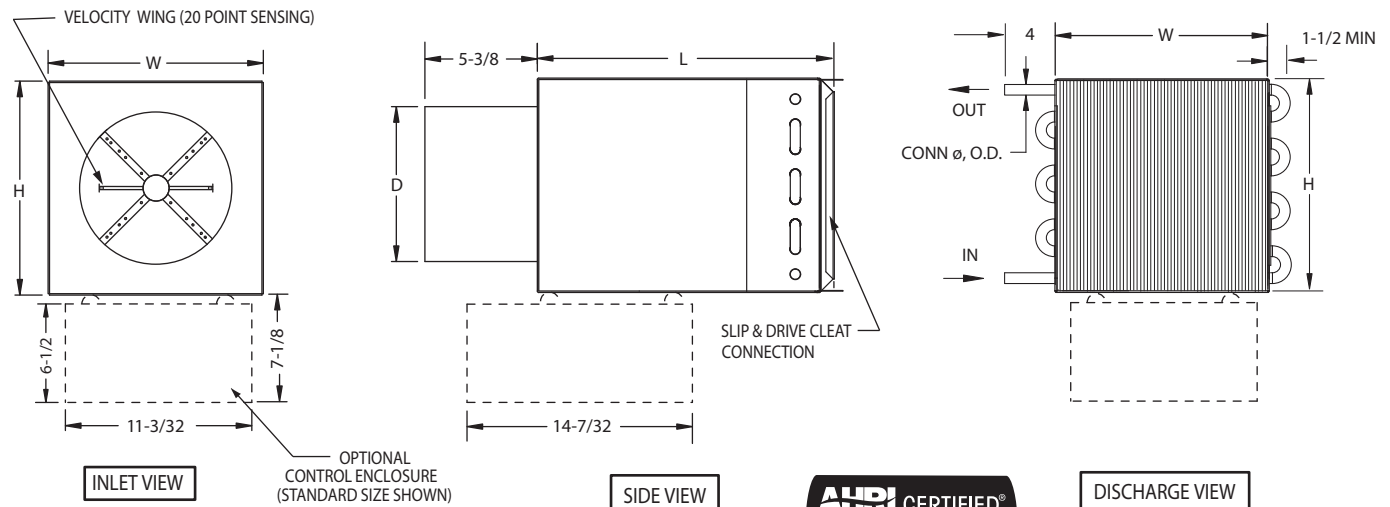

All dimensions are in inches.

Unit Size	Airflow Range, CFM	Inlet Dia D	W	H	1 Row Coil			2 Row Coil			3 Row Coil			4 Row Coil		
					L	Conn Ø, O.D.	Weight	L	Conn Ø, O.D.	Weight	L	Conn Ø, O.D.	Approx Weight	L	Conn Ø, O.D.	Approx Weight
05	0 - 290	4-7/8	10	10	15-5/8	1/2	25	16-11/16	1/2	27	17-3/4	7/8	30	19-5/16	7/8	33
06	0 - 470	5-7/8	10	10	15-5/8	1/2	25	16-11/16	1/2	27	17-3/4	7/8	30	19-5/16	7/8	33
07	0 - 615	6-7/8	12	10	15-5/8	1/2	27	16-11/16	1/2	30	17-3/4	7/8	34	19-5/16	7/8	37
08	0 - 870	7-7/8	12	10	15-5/8	1/2	27	16-11/16	1/2	30	17-3/4	7/8	34	19-5/16	7/8	37
09	0 - 1100	8-7/8	14	12-1/2	17-5/8	1/2	38	18-11/16	1/2	41	19-3/4	7/8	47	21-5/16	7/8	52
10	0 - 1355	9-7/8	14	12-1/2	17-5/8	1/2	38	18-11/16	1/2	41	19-3/4	7/8	47	21-5/16	7/8	52
12	0 - 1800	11-7/8	16	15	21-5/8	7/8	45	22-11/16	1/2	49	23-3/4	7/8	56	25-5/16	7/8	63
14	0 - 2470	13-7/8	20	17-1/2	21-5/8	7/8	54	22-11/16	7/8	61	23-3/4	7/8	69	24-13/16	7/8	78
16	0 - 3370	15-7/8	24	17-1/2	21-5/8	7/8	64	22-11/16	7/8	72	23-3/4	7/8	82	24-13/16	7/8	93

NOTES:

1. ONLY SIDE ACCESS DOOR AVAILABLE. STANDARD LOCATION IS H.W. COIL CONNECTION SIDE.
2. AIRFLOW RANGE SHOWN IS FOR SENSOR dP = 1.00". CONSULT VAV CONTROLLER SPECIFICATIONS FOR ACTUAL MIN AND MAX dP LIMITS.
3. WEIGHT SHOWN IS TOTAL ASSEMBLY WET WEIGHT IN LBS (8.3 LBS / GALLON)
4. OPTIONAL CONTROL ENCLOSURE LOCATION WILL VARY BASED ON CONTROLS INSTALLED.

JOB NAME:

SUBMITTED BY:

BOTTOM CONTROLS

SUBMITTAL SHEET

www.anemostat-hvac.com

SIZE 24 X 16

PRODUCT FEATURES

- AHRI 880 certified
- 20 gauge zinc-coated steel, low leakage casing construction sealed to limit leakage to <1% of max rated flow at 3" w.g. static pressure.
 - Optional: Ultra Lo-Leak construction
- 1/2" dual density insulation (NFPA 90A, UL 181).
 - Optional: 1" dual density glass fiber insulation
 - 1/2" 1" foil faced glass fiber insulation – metal taped edges (ASTM C665)
 - 3/8" fiber free closed cell foam insulation (NFPA255, UL181)
 - 1/2" 1" dual wall construction
 - Lo-Temp casing construction
 - 1" Fibre-Lok : High density foil-faced duct board with steel encapsulated edges (ASTM C665)
 - No insulation
- 1, 2, 3, or 4 row hot water coils with 1/2" o.d. copper tubes thru aluminum corrugated fins @ 10 per inch. Right or Left Hand coil connections.
- 90° multi-blade inlet damper with leak resistant perimeter and jamb seals limiting leakage to <1% of max rated flow @ 3" w.g. inlet static pressure.
- Multi-Point center averaging Velocity Wing air flow sensor for accuracy to ± 5% of design flow. Optional Flow Taps / Tees
- Slip & drive cleat discharge connection.
- Optional Accessories:
 - 6 x 6 Access Plate 6 x 6 Access Door Bottom Side
 - Hinged Double Camlock
 - Unit mounting brackets (field installed)
 - Standard control enclosure Large control enclosure
 - Screw attached cover Hinged cover
- Control System : Digital Electronic Analog Pneumatic Electric
 - None – No controls By ATC - Factory Installed
 - By Anemostat By ATC - Field Installed

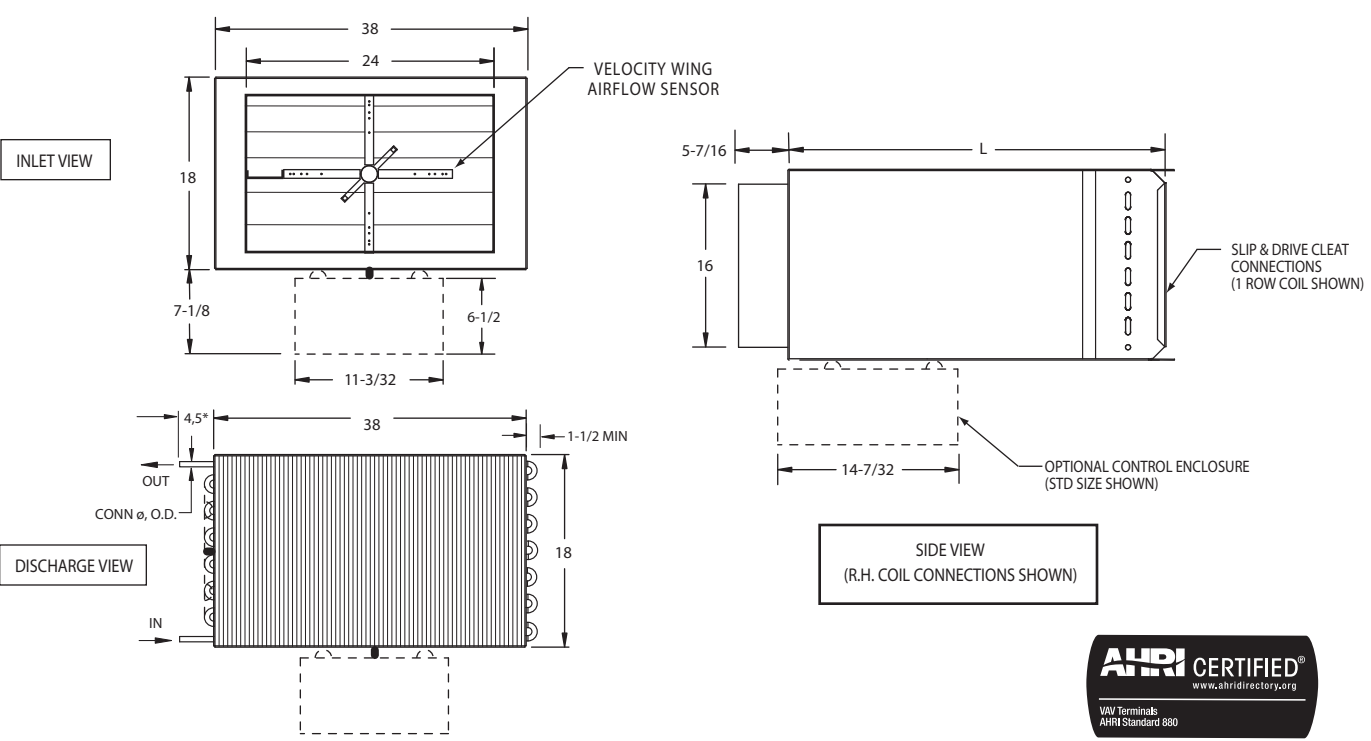

All dimensions are in inches.

Unit Size	Airflow Range, CFM	1 Row Coil			2 Row Coil			3 Row Coil			4 Row Coil		
		L	Conn Ø, O.D.	Weight	L	Conn Ø, O.D.	Weight	L	Conn Ø, O.D.	Approx Weight	L	Conn Ø, O.D.	Approx Weight
24x16	0 - 6360	35	7/8	124	35	7/8	136	36	1-1/8	153	36	1-1/8	169

NOTES:

1. AIRFLOW RANGE SHOWN IS FOR SENSOR dP = 1.00". CONSULT VAV CONTROLLER SPECIFICATIONS FOR ACTUAL MIN AND MAX dP LIMITS.
2. WEIGHT SHOWN IS TOTAL ASSEMBLY WET WEIGHT IN LBS (8.3 LBS / GALLON)
3. OPTIONAL CONTROL ENCLOSURE LOCATION WILL VARY BASED ON CONTROLS INSTALLED.
4. HEADER DIMENSION FROM SIDE OF COIL IS 4" FOR 1, 2 ROW, AND 5" FOR 3, 4 ROW COILS.

JOB NAME:

SUBMITTED BY: