

# Anemostat®

## SUBMITTAL

A MESTEK COMPANY

1220 Watson Center Road • Carson, CA 90745-4206  
 (310) 835-7500 • FAX (310) 835-0448  
 air@anemostat.com • www.anemostat.com



### Model **F3P**

## HINGED RETURN FILTER GRILLE

### PERFORATED LAY-IN T-BAR

# GRILLES & REGISTERS

### PRODUCT FEATURES

- Perforated, 51% free area
- Piano Hinge Construction
- 1/4-Turn Latch(es). Qty=2 on size 24" & up
- Concealed fastening thru neck of grille
- Sizes 6" x 4" to 48" x 48" maximum single piece construction
- Recommended Filter Size (Actual) = Grid Module Size -3-1/8"

### CONSTRUCTION DETAILS

#### Material:

- Steel
- 304 Stainless Steel

#### Finish:

- Arctic White
- Satin Polish
- Custom Color \_\_\_\_\_

AVAILABLE SIZES	
MODULE SIZE	DUCT SIZE
12 x 12	10 x 10
12 x 24	10 x 22
24 x 24	22 x 22
24 x 48	22 x 46

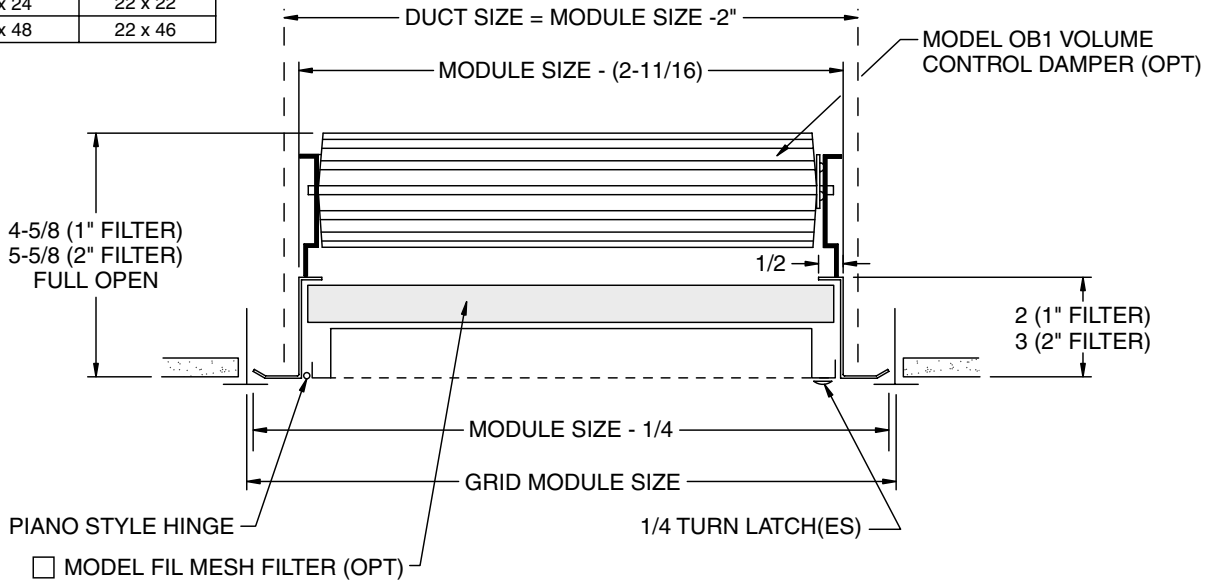

MODEL	FILTER SIZE	TYPE	DUCT (W X H)	APPLICATION	MODULE
<b>F3P</b> Perforated	<b>1L</b>	<b>H</b> Hinged Core	<b>22.00 / 22.00</b>	<b>L</b> Inverted T-Bar, 15/16"	<b>22</b>
	1 1" Filter				- N/A
	2 2" Filter				11 12" x 12"
	1S 1" Filter, Hinge on Short Dim.				12 12" x 24"
	1L 1" Filter, Hinge on Long Dim.				22 24" x 24"
	2S 2" Filter, Hinge on Short Dim.				24 24" x 48"
	2L 2" Filter, Hinge on Long Dim.				

Dimensions are in inches (millimeters).

JOB NAME:

SUBMITTED BY: