

SUBMITTAL SHEET

PRODUCT FEATURES

- 1/2" x 1/2" x 1/2" aluminum core
- Registers include a factory attached, steel opposed blade volume control damper

CONSTRUCTION DETAILS

Material: All Steel Components with Aluminum Core (**std**)

Finish:

- Arctic White (**std**)
- Custom Color (opt)

ACCESSORIES

- OB1-ST** (Steel Opposed Blade Volume Control Damper)
- OB1-AL** (Aluminum Opposed Blade Volume Control Damper)
- SRA** Square to Round Adapter, Steel
- VD** Volume Damper, Butterfly Type, Steel (used with SRA)

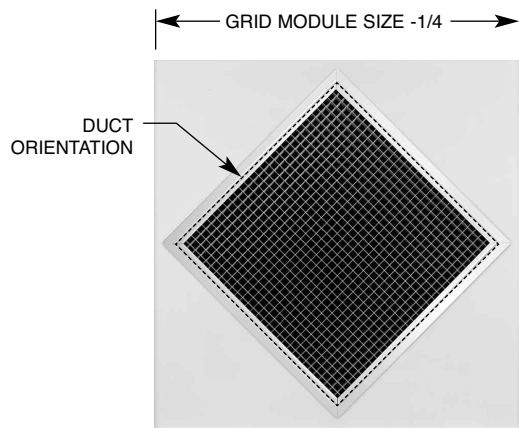

AVAILABLE DUCT SIZES	OPTIONAL SRA MAX Ø
6 x 6	6" Ø
8 x 8	8" Ø
10 x 10	10" Ø
12 x 12	12" Ø
14 x 12	14" Ø

GRID MODULE SIZE	MAX NECK SIZE
24 x 24	14 x 14

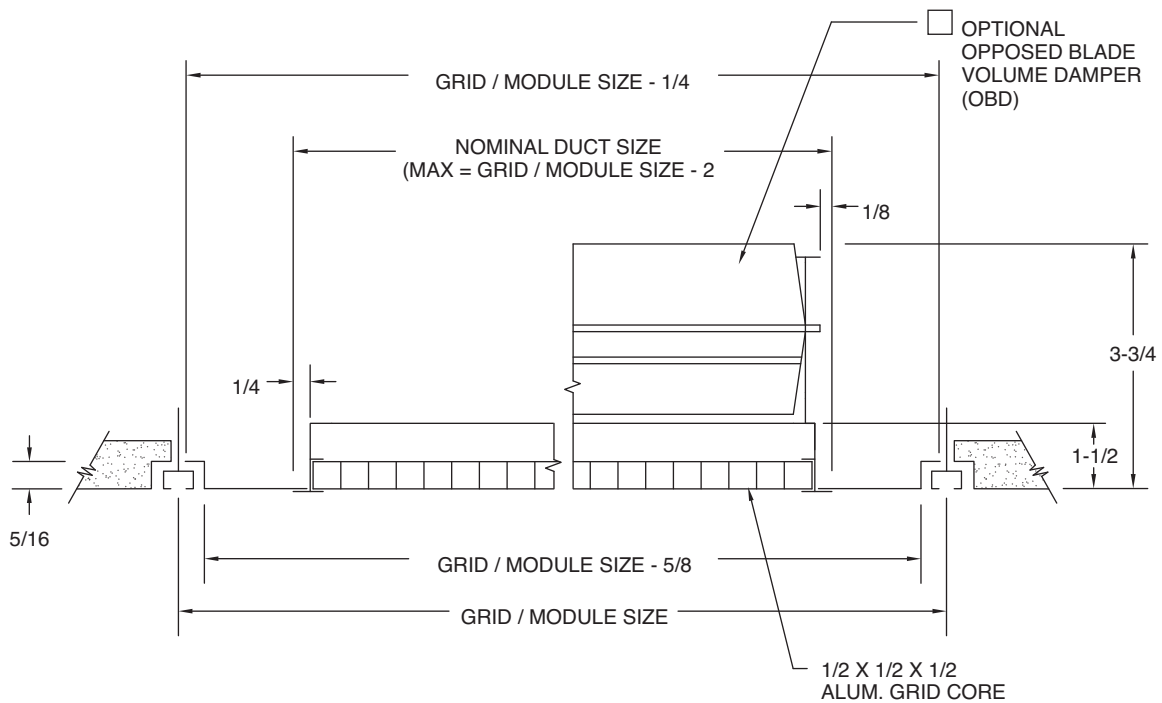

All dimensions are in inches.

JOB NAME:

SUBMITTED BY: