

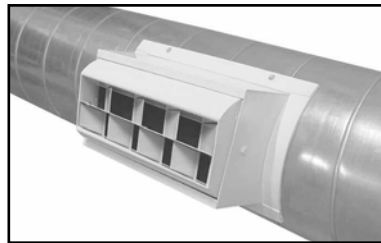

Anemostat®
AIR DISTRIBUTION

SUBMITTAL SHEET

www.anemostat-hvac.com



Model **EcoJet**
DRUM LOUVER
SPIRAL DUCT MOUNT
SPLIT VANE DRUM LOUVER

PRODUCT FEATURES

- Long throw capability ideally suited for large spaces
- 0° to ±30° Drum Rotation
- #8 sheet metal screws factory provided

CONSTRUCTION DETAILS

Material: Extruded Aluminum

Finish:

Arctic White

Optional Finishes:

Natural Anodize

Custom Color:

MODELS

EJ-D Split Vane Drum Louver

EJ-D-P Split Vane Drum Louver with Pole Operator

Volume Damper:

None

Diverter (must be factory installed)

OB-1 Opposed Blade Damper

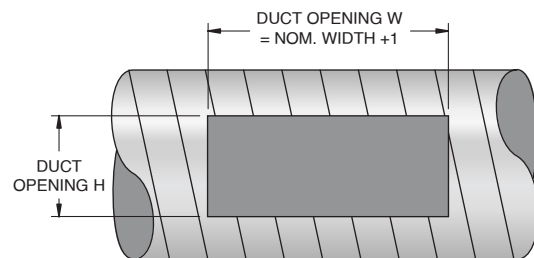
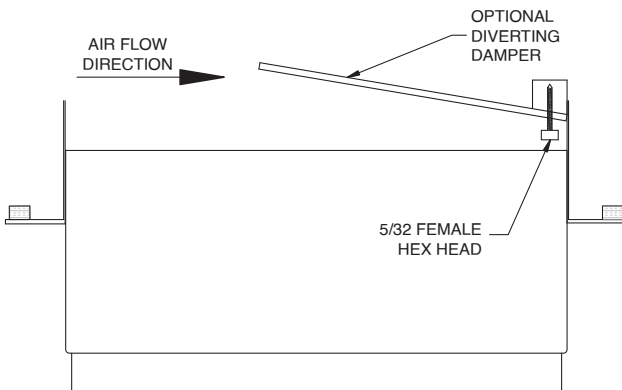
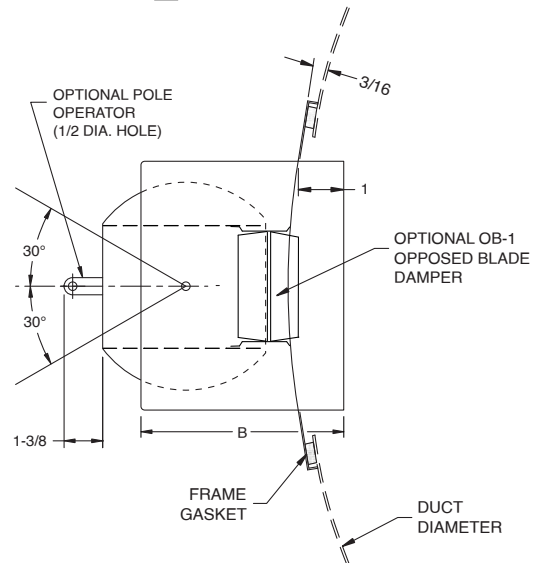
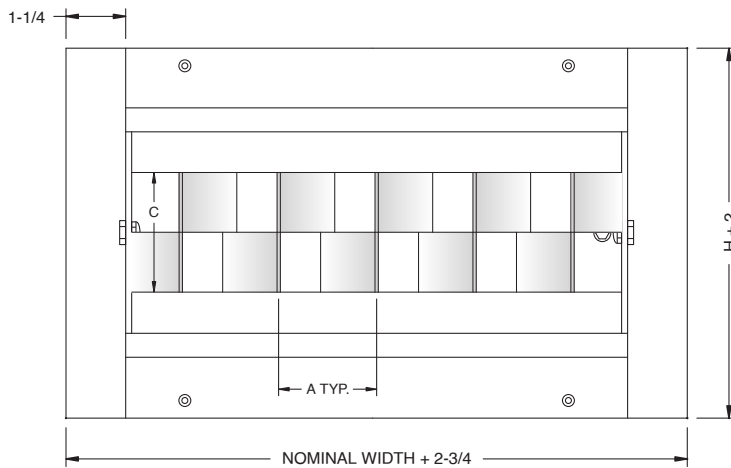

MODEL EJ / EJ-P						
NOM HEIGHT (DRUM DIA)	MIN DUCT DIA	A	B	C	DUCT OPENING	
					W	H
06"	10	3	5-3/4	3-7/16	NOM W + 1	7"
10"	15	5	8-1/2	5-15/16	NOM W + 1	11"
12"	18	5	7-1/2	6-13/16	NOM W + 1	13"
15"	22	5	6-1/2	9-3/4	NOM W + 1	16"

6"	10"	12"	15"
W x H	W x H	W x H	W x H
9x6	20x10	20x12	15x15
12x6	25x10	25x12	20x15
18x6	30x10	30x12	25x15
24x6	35x10	35x12	30x15
30x6	40x10	40x12	40x15
36x6	50x10	50x12	50x15
48x6	60x10	60x12	60x15
60x6	70x10	70x12	70x15

All dimensions are in inches.

JOB NAME:

SUBMITTED BY: