



**Anemostat®**  
AIR DISTRIBUTION

MODEL **LA681M**

**EXTRUDED ALUMINUM LOUVERS**  
COMBINATION ADJUSTABLE AND STATIONARY 6" DEEP

35° STRAIGHT STATIONARY BLADE - CONCEALED ACTUATOR

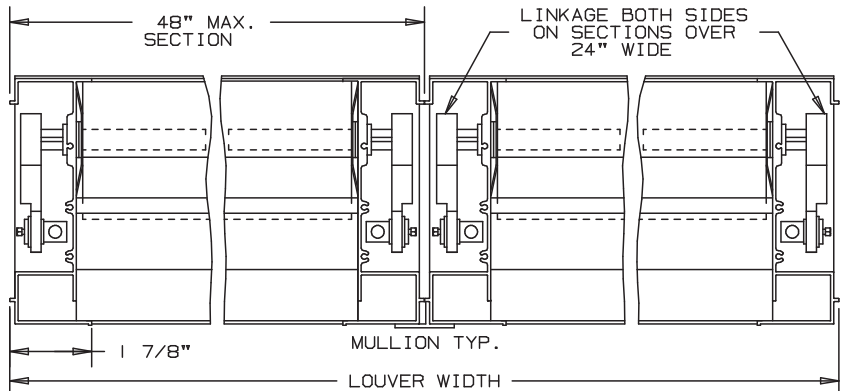
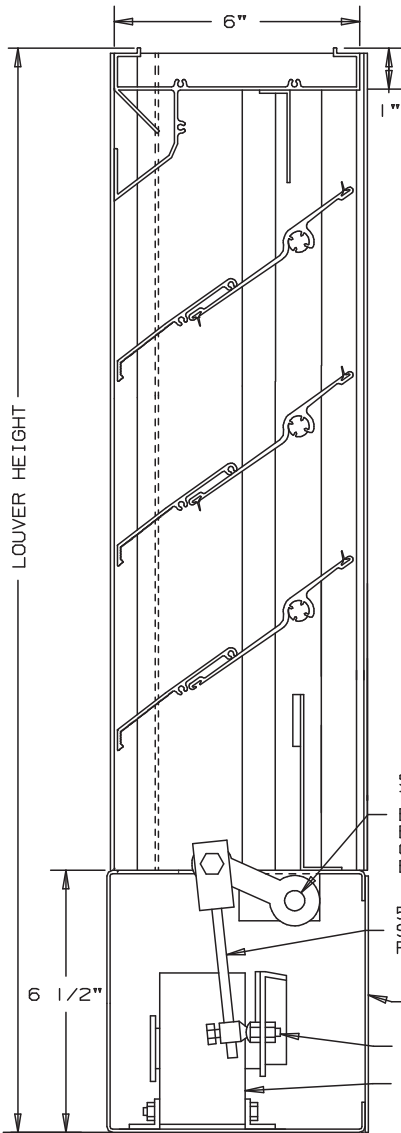

1/2" DIA. STEEL TORSION BAR WITH BRONZE OILITE BEARINGS

5/16" DIA. STEEL DRIVE ROD

REMOVABLE ALUMINUM COVER PLATE

BALL SWIVEL

ELECTRIC ACTUATOR

FORMED ALUMINUM SILL (.081")

NOT TO SCALE

**SPECIFICATIONS**  
BEARINGS: CELCON BEARING MATERIAL SO THAT THERE WILL BE NO METAL TO METAL FRICTION. OPERATING LINKAGE CONCEALED IN FRAME, OUT OF THE AIR STREAM.  
FRAME AND STATIONARY BLADE: EXTRUDED ALUMINUM 6063-T6/T52 ALLOY, FRAME IS .080" THK., BLADE IS .080" THK. ON 4 1/2" CENTERS.  
ADJUSTABLE BLADE: EXTRUDED ALUMINUM 6063-T6/T52 ALLOY, .125" THK.  
FACE OF LOUVER: FULL WIDTH SILL WITH HEAD AND BLADES CONTAINED WITHIN THE JAMBS.  
LINKAGE: EXTRUDED ALUMINUM, CONCEALED IN CHANNEL OUT OF AIRSTREAM. PIVOTS ARE .050" DIA. MACHINED STEEL, CADMIUM PLATED AND CHROMATE TREATED. PIVOTS ROTATE IN A CELCON BEARING. A .312" DIA. ALUMINUM LINKAGE ROD IS LOCKED TO THE PIVOT BY A 1/4-20 SET SCREW WITH AN EPOXY LOCKING PATCH.  
SHAFTS: .50" DIA. ALUMINUM "PIN-LOCK" ROD.  
SEALS: EXTRUDED SILICONE RUBBER SEAL AT BLADE EDGE. STAINLESS STEEL AT JAMB.  
SCREENS: WHEN INDICATED, IN A REMOVABLE FRAME.  
BIRD SCREEN - 1/2" FLATTENED ALUMINUM, .051" THK.  
OR - 1/2" SQ. MESH, INTERMEDIATE DOUBLE-CRIMPED ALUMINUM WIRE, .063 DIA.  
OR - 18/16 MESH, .011" DIA. ALUMINUM WIRE, INSECT SCREEN.  
FINISH: MILL.  
ACTUATOR: 120 VAC, SPRING RETURN NORMALLY CLOSED  
133 IN.-LBS. TORQUE  
LOUVER SIZES: 12" x 19" MINIMUM PANEL SIZE.  
48" x 96" MAXIMUM PANEL SIZE.

**OPTIONAL**

- OTHER SCREENS
- ARCHITECTURAL FINISHES

NOMINAL DEDUCTIONS WILL BE MADE TO THE OPENING SIZE GIVEN.

										 UNION MADE
ITEM	QTY.	WIDTH	HEIGHT	WIDTH	HEIGHT	MULL	TYPE	LOC		
		OPENING SIZE		LOUVER SIZE			SCREENS			

**Anemostat Air Distribution**  
1220 E. Watson Center Road  
Carson, CA 90745  
310-835-7500 • air@anemostat.com  
www.anemostat-hvac.com

AGENT: \_\_\_\_\_

ARCH. /ENG. :
CONTR. :
PROJECT :
EDR: _____ ECN: _____ JOB: _____
DATE: _____ DWN. : _____ DWG. : _____