



Anemostat®
AIR DISTRIBUTION

MODEL **SL15B**

EXTRUDED ALUMINUM LOUVERS
1-1/2" DEEP

30° BAFFLE BLADE-STATIONARY-CHANNEL TYPE

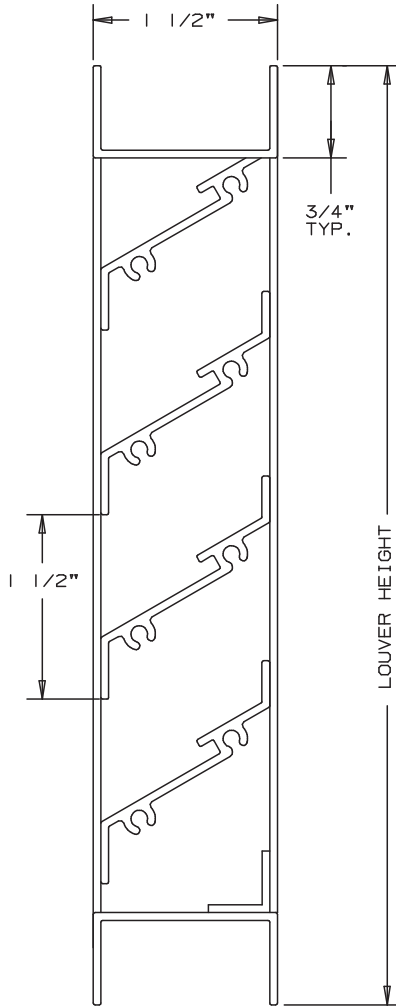

NOT TO SCALE

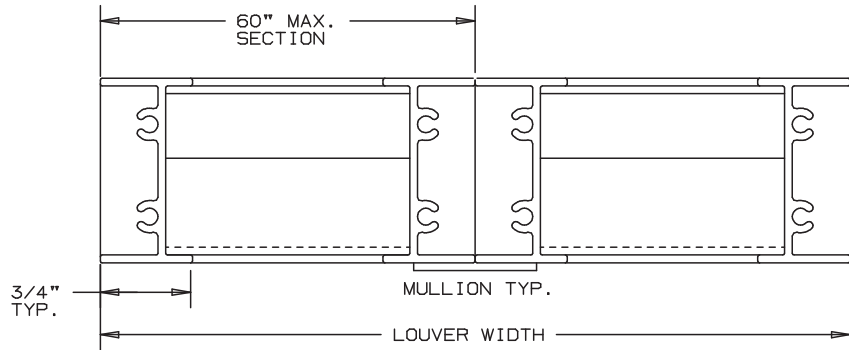

SPECIFICATIONS

MATERIAL: EXTRUDED ALUMINUM 6063-T6/T52 ALLOY, .063" THK.

FACE OF LOUVER: ALL SURFACES ARE FLUSH WITH JAMBS CONTAINED WITHIN THE HEAD AND SILL.

SCREEN: (WHEN INDICATED, IN A REMOVABLE FRAME)
 BIRD SCREEN - 1/2" FLATTENED ALUMINUM, .051" THK.
 OR - 1/2" SQ. MESH INTERMEDIATE DOUBLE-CRIMPED ALUMINUM WIRE, .063" DIA.
 OR - 18/16 MESH, .011" DIA. ALUMINUM WIRE INSECT SCREEN.

FINISH: _____

MINIMUM PANEL SIZE: 12" x 12"
 MAXIMUM SINGLE PANEL SIZE: 60" x 96"

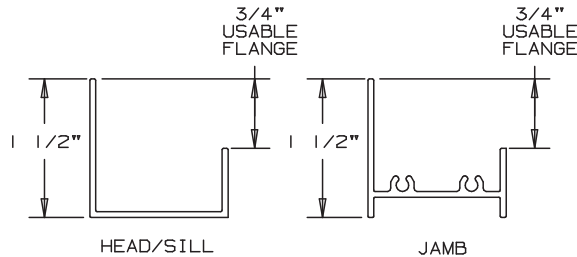

FLANGE FRAME OPTION

FOR PERFORMANCE DATA
-SEE REVERSE SIDE

NOMINAL DEDUCTIONS WILL BE MADE TO OPENING SIZES GIVEN.

ITEM	QTY.	WIDTH	HEIGHT	WIDTH	HEIGHT	MULL	TYPE	LOC	SCREENS	UNION MADE
		OPENING SIZE		LOUVER SIZE						



Anemostat Air Distribution
 1220 E. Watson Center Road
 Carson, CA 90745
 310-835-7500 • air@anemostat.com
 www.anemostat-hvac.com

AGENT: _____

ARCH./ENG.:	
CONTR.:	
PROJECT:	
EDR:	ECN: JOB:
DATE:	DWN.: DWG.:

MODEL SL15B

30° BAFFLE BLADE

EXTRUDED ALUMINUM - STATIONARY

PERFORMANCE DATA

TESTS OF A 48" X 48" SAMPLE BY AN *AMCA REGISTERED LABORATORY
 ACCORDING TO AMCA STANDARD 500 SHOWS LESS THAN .02 OZ. PER SQ. FT.
 WATER PENETRATION AT 495 FPM (FREE AREA VELOCITY) WITH LESS THAN
 .034" W.G. PRESSURE DROP (INTAKE).
 DROP (INTAKE).

RATINGS DO NOT INCLUDE THE EFFECT OF BIRDSCREEN.

PRESSURE DROP

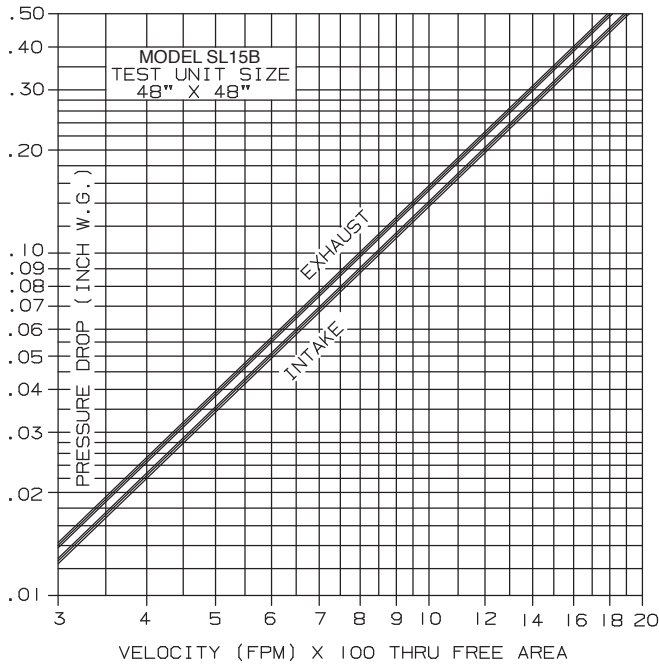

WATER PENETRATION

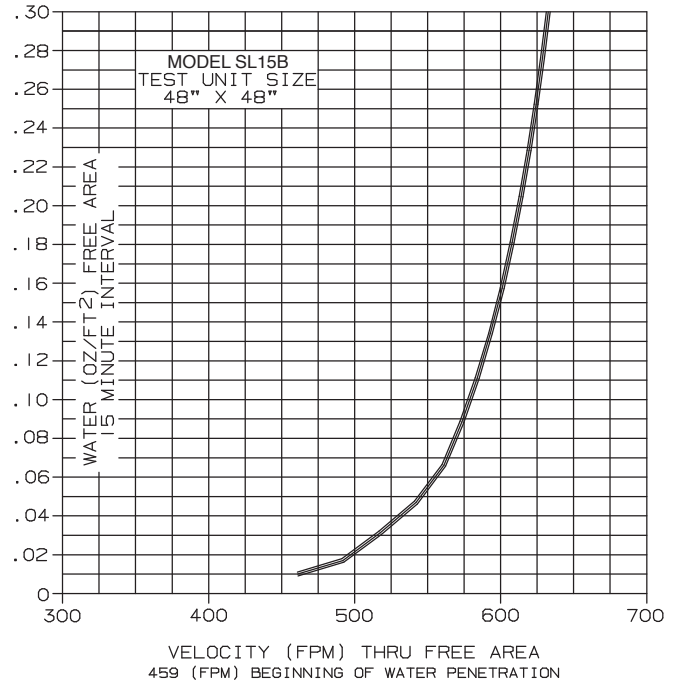

FREE AREA

		FREE AREA (SQ. FT.)								
		WIDTH								
		12"	18"	24"	30"	36"	42"	48"	54"	60"
HEIGHT	12"	.33	.52	.71	.90	1.09	1.28	1.47	1.66	1.85
	24"	.78	1.22	1.66	2.11	2.55	2.99	3.44	3.88	4.32
	36"	1.22	1.92	2.61	3.31	4.01	4.70	5.40	6.10	6.80
	48"	1.66	2.61	3.56	4.52	5.47	6.42	7.37	8.32	9.27
	60"	2.11	3.31	4.52	5.72	6.92	8.13	9.33	10.54	11.74
	72"	2.55	4.01	5.47	6.93	8.38	9.84	11.30	12.76	14.22
84"	3.00	4.71	6.42	8.13	9.84	11.55	13.27	14.98	16.69	
96"	3.44	5.40	7.37	9.34	11.30	13.27	15.23	17.20	19.16	

* AMCA REGISTERED LABORATORY IS A LABORATORY EQUIPPED AND STAFFED TO CONDUCT TESTS ACCORDING TO THE APPROPRIATE AMCA TESTS METHOD AND WHICH HAS BEEN LICENSED AS A AMCA REGISTERED LABORATORY.