



# Anemostat®

## SUBMITTAL

A MESTEK COMPANY

1220 Watson Center Road • Carson, CA 90745-4206  
 (310) 835-7500 • FAX (310) 835-0448  
 airhelp@anemostat.com • www.anemostat.com

### Model **MVCF**

## PERIMETER AIR CURTAIN

### FOR AORTA

### OPERATING ROOM SYSTEMS

### WITH HEPA FILTER - TOP INLET

## DIFFUSERS

### PRODUCT FEATURES

- Perimeter diffuser establishes an outward air curtain between a 5°-15° discharge angle
- Fixed pattern created by stamped control flaps for predictable performance – outperforms slot configurations for directional control
- Filter interface includes knife edge into filter gel seals for zero leak performance
- 4 capacity ranges available for extreme design flexibility - system 31, 42, 53, and 64
- Dual chamber design means stable performance regardless of inlet condition or damper position.
- Removable face via 1/4 turn fasteners for cleaning
- Face is hinged and swings down 90° for easy cleaning. Safety cables prevent face from accidentally swinging down.
- Closed cell gasket prevents leakage around face

### MATERIAL AND FINISH

#### Face:

- Steel with White Baked Epoxy
- Aluminum with White Baked Epoxy
- 304 Stainless Steel, #4 Polish
- 304 Stainless Steel with White Baked Epoxy

#### Backpan / Plenum:

- Steel with White Baked Epoxy
- Aluminum with White Baked Epoxy
- 304 Stainless Steel, 2B Mill Finish
- 304 Stainless Steel with White Baked Epoxy

### MODELS

- MVCF-T** Lay-In T-Bar (Top Inlet)
- MVCF-P** Surface Mounted (Top Inlet)

### CAPACITY

- 31       53
- 42       64

### ACCESSORIES

- Light Alert** Filter Monitoring System

MVCF DIMENSIONS	
Nom. Length	Max Size
24	9" DIA
36	
48	
60	
72	

**Model MVCF-T**  
Lay-In T-Bar  
(Top Inlet)

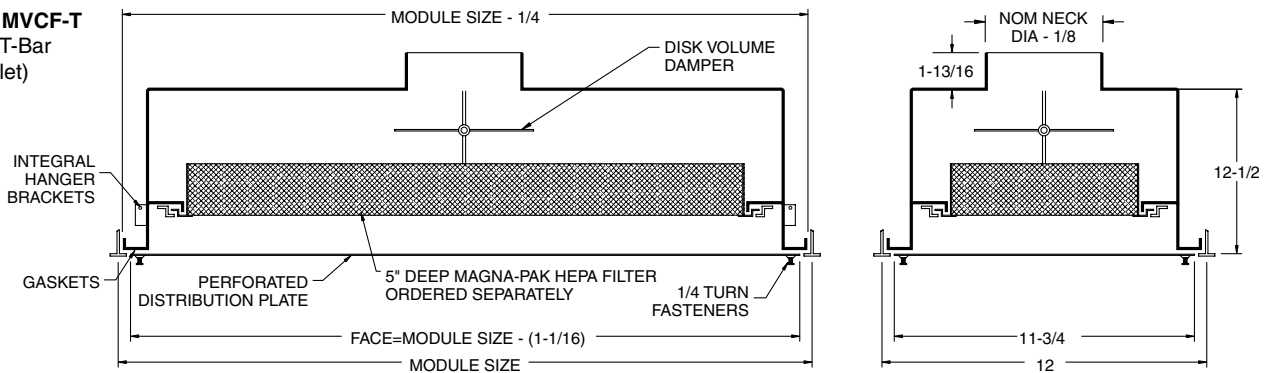

**Model MVCF-P**  
Surface Mounted

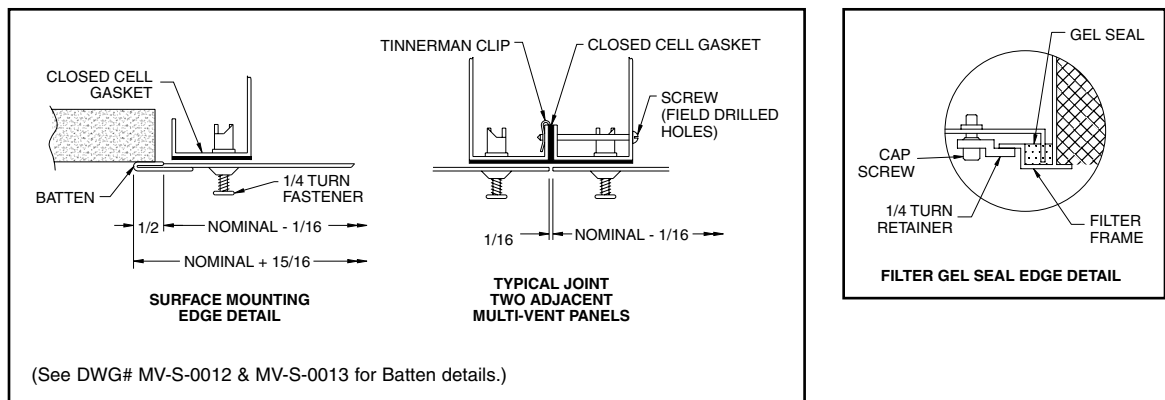

All dimensions are in inches.

**JOB NAME:**

**SUBMITTED BY:**