

SUBMITTAL SHEET

www.anemostat-hvac.com

Model **PGC**
PARAGON DIFFUSER
SUPPLY / RETURN
24 x 24 CONCEALED GRID / SPLINE
APPLICATIONS

PRODUCT FEATURES

- Optional volume control damper, accessible from room side
- Removable inner plaque assembly
- Optional blankoff baffles, field installed
- Designed for use with 15/16" concealed / spline type suspended grid systems

CONSTRUCTION DETAILS

Material: Cold Rolled Steel (std)

- Aluminum (opt)
- 304 Stainless Steel (opt)

Finish: White (std)

- Custom Colors (opt)

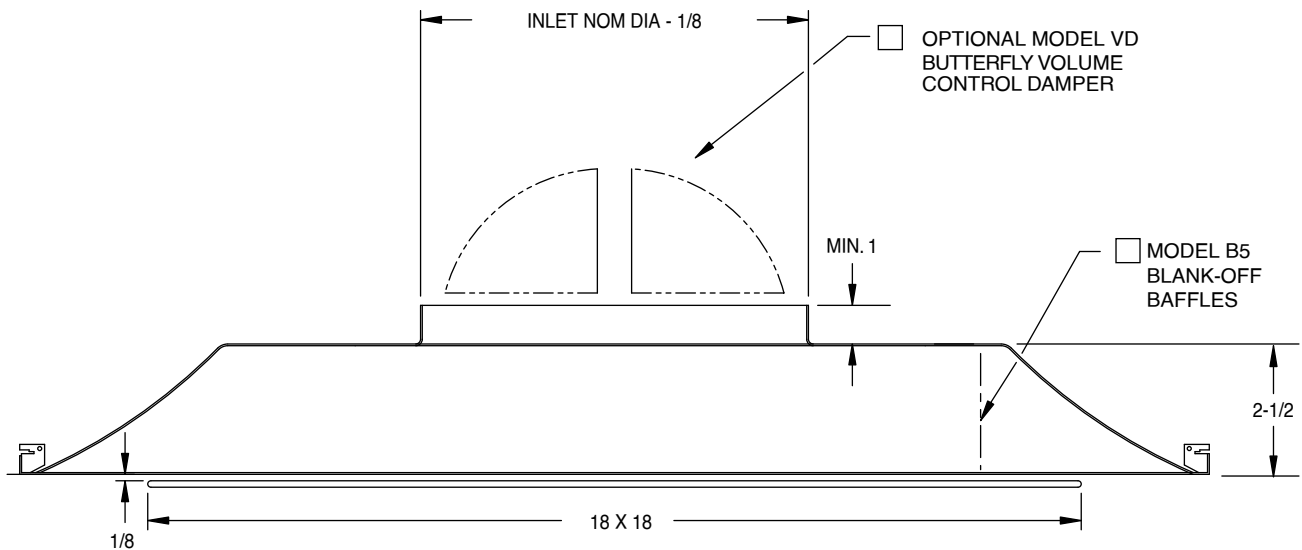

AVAILABLE INLET SIZES
4Ø
5Ø
6Ø
8Ø
10Ø
12Ø
14Ø
15Ø

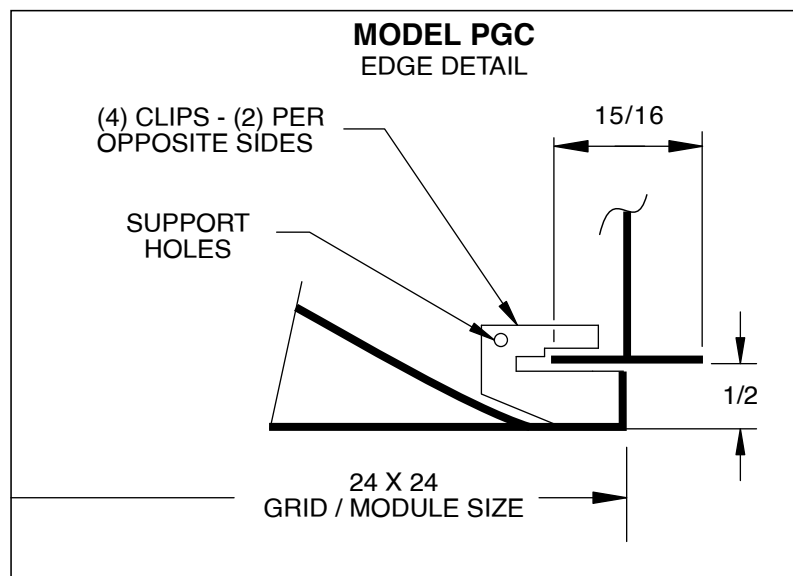

All dimensions are in inches.

JOB NAME:

SUBMITTED BY: