

# Anemostat® SUBMITTAL

1220 Watson Center Road • Carson, CA 90745-4206  
(310) 835-7500 • FAX (310) 835-0448  
air@anemostat.com • www.anemostat-hvac.com

Model **RF-7**  
**RETROFIT**  
FLOW SENSING  
STATION

## AIR TERMINALS

### PRODUCT FEATURES

- Use with external retrofit solutions for air flow measurement.
- Round in - round out connections sized for use with round hard duct and/or flexible duct.
- Patented Velocity Wing sensor for accurate flow readings.
- Galvanized steel collar for common round duct installations.
- Insulated by installing contractor after installation as required.

### CONSTRUCTION DETAILS

#### Material:

- Galvanized Steel
- Aluminum
- 304 Stainless Steel

VELOCITY  
WING

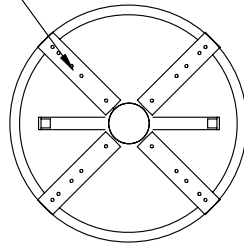

INLET VIEW

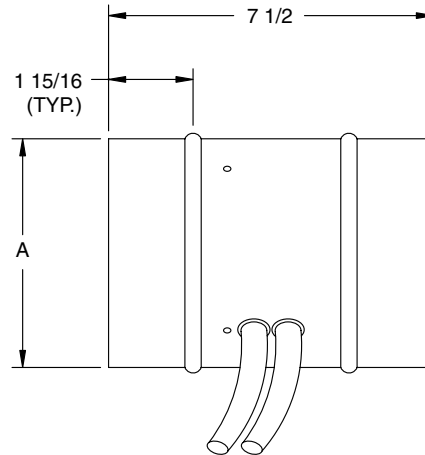

SIDE VIEW

SIZE	A,ø	AIR FLOW RANGE, CFM*
5	4-7/8	0 - 290
6	5-7/8	0 - 470
7	6-7/8	0 - 610
8	7-7/8	0 - 865
9	8-7/8	0 - 1100
10	9-7/8	0 - 1355
12	11-7/8	0 - 1800
14	13-7/8	0 - 2470
16	15-7/8	0 - 3365

\*FLOW RANGE BASED ON ΔP = 0 - 1.0" W.G.

All dimensions are in inches.

JOB NAME:

SUBMITTED BY: