

# SUBMITTAL SHEET

www.anemostat-hvac.com



Model **E30-L**  
**ENHANCED CAPACITY**  
**FIXED BLADE RETURN**

3/4" SPACING/40° DEFLECTION  
LAY-IN T-BAR (15/16")  
WITH EXTENSION PANEL

### PRODUCT FEATURES

- Fixed louver return
- Duct size independent of grid module size
- Registers include a factory attached, opposed blade volume control damper

### ACCESSORIES

- OB-1-ST OB Damper (Steel)
- OB-1-AL OB Damper (Alum)
- OB-2-04 OB Damper (Stn Stl)

### CONSTRUCTION DETAILS

Material:

- Steel (ST)
- Aluminum (AL)
- 304 Stainless Steel (04)

Finish:

- Arctic White (WH - standard)
- Satin Polish (Stn Steel Only)
- Custom Color \_\_\_\_\_

### EXTENSION PANEL SIZES

- 06" x 30" Module (A)
- 06" x 48" Module (B)
- 12" x 12" Module (11)
- 12" x 24" Module (12)
- 24" x 24" Module (22)
- 24" x 48" Module (24)
- 30" x 30" Module (30)
- Other \_\_\_\_\_

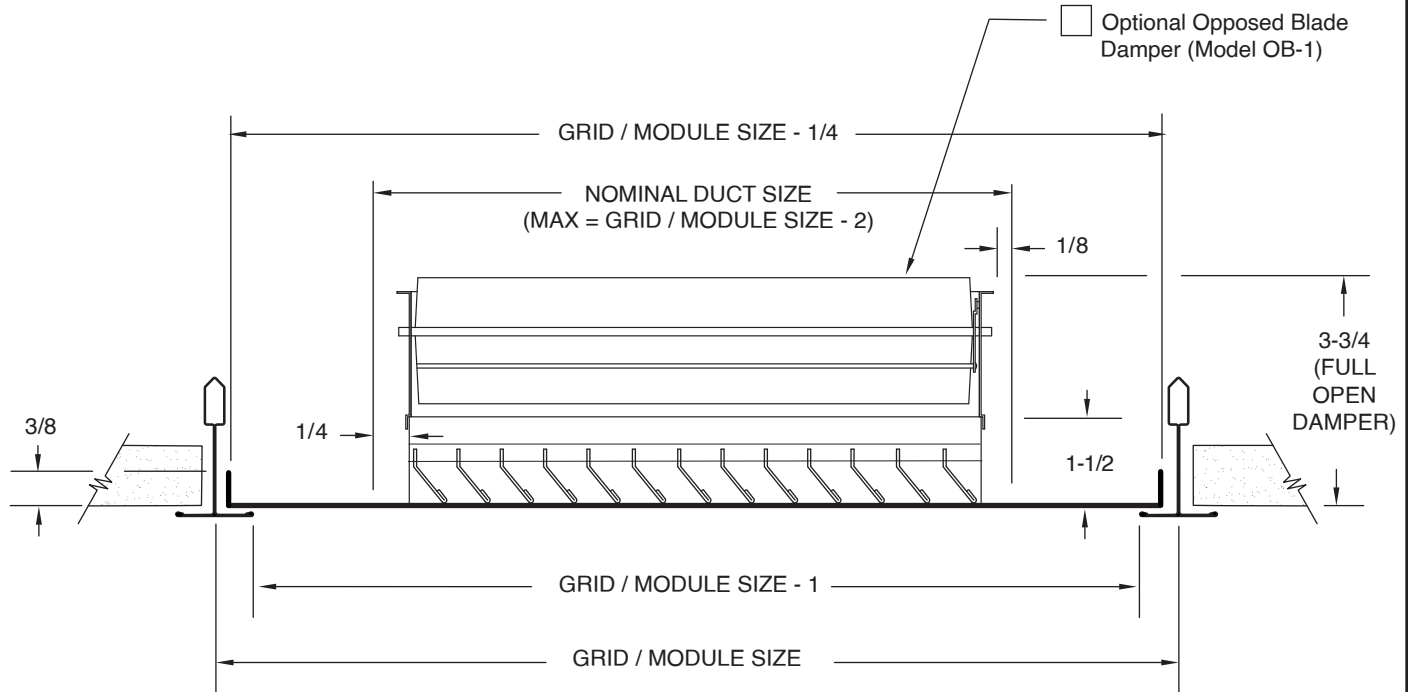

GRID / MODULE SIZE	MAX NECK SIZE
12 x 12	10 x 10
12 x 24	10 x 22
24 x 24	22 x 22
24 x 48	22 x 46
48 x 48	46 x 46

**NOTE:** Louvers are parallel to longer neck dimension as standard.

All dimensions are in inches.

JOB NAME:

SUBMITTED BY: