

APPLICATION

- Series type, fan assisted air terminal proportions primary air and ceiling plenum air
- Maintain space temperature with constant air flow delivery to the space throughout the operating range for high levels of thermal comfort.
- Energy reclamation from warmer ceiling plenum during heating cycles.
- Improved air quality with high levels of air motion for significant occupant comfort.
- Control strategies using pneumatic, analog, or direct digital control (DDC) systems

FEATURES

- Efficient, 3 Speed motor (permanent split capacitor) with thermal overload protection allows horsepower change for greatest potential of energy savings. 120 or 277 vac, 1ø
- Solid state speed controller with factory calibrated minimum voltage setting for precision air flow adjustment.
- Ultra-Quiet, 18 & 20 gauge zinc-coated steel design for rigidity and demanding noise criteria specifications. Standard terminal includes an acoustical attenuator – not an “add on” accessory!!
- 1” dual density thermal / acoustic internal insulation (NFPA 90A & UL 181)
- Easy to install and service – all controls located in one convenient location for single point electrical connection.
- Swing-down fan access panel
- Steel control enclosure, screw attached cover. Left hand position is standard.
- 90° inlet damper & perimeter seal limiting leakage to <1% of max rated flow at 3” w.g. inlet static pressure.
- Patented Velocity Wing primary flow sensor measures flow to ±5% accuracy regardless of inlet conditions. Highest velocity pressure amplification means high turn down with high accuracy.
- AHRI 880 certified performance / ETL listed (UL 1995).
- Accepts flanged discharge duct connection

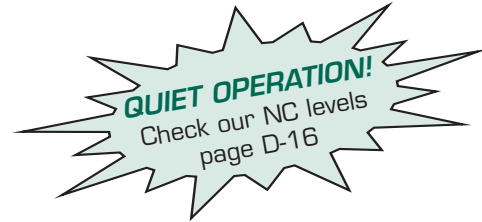

OPTIONS & ACCESSORIES

- Model Q5 radiated sound elbow
- Hinged front control enclosure cover
- Internal Insulation - 1/2" or 1" foil-faced glass fiber insulation with metal taped edges meeting ASTM C665, double wall construction, Lo-Temp casing construction, 3/8" fiber free closed cell foam insulation, no insulation, see page A-11.
- Slip & drive cleat discharge collar
- 1" Throw-away filter & filter rack
- Unit mounting brackets (field installed)
- Electrical component options – line voltage disconnect switch, power fusing, 3-speed manual motor selector switch, electric damper actuator (24vac) for use with DDC controls, fan relay for on-off function, 24vac step down transformer
- Digital, analog, or pneumatic control systems

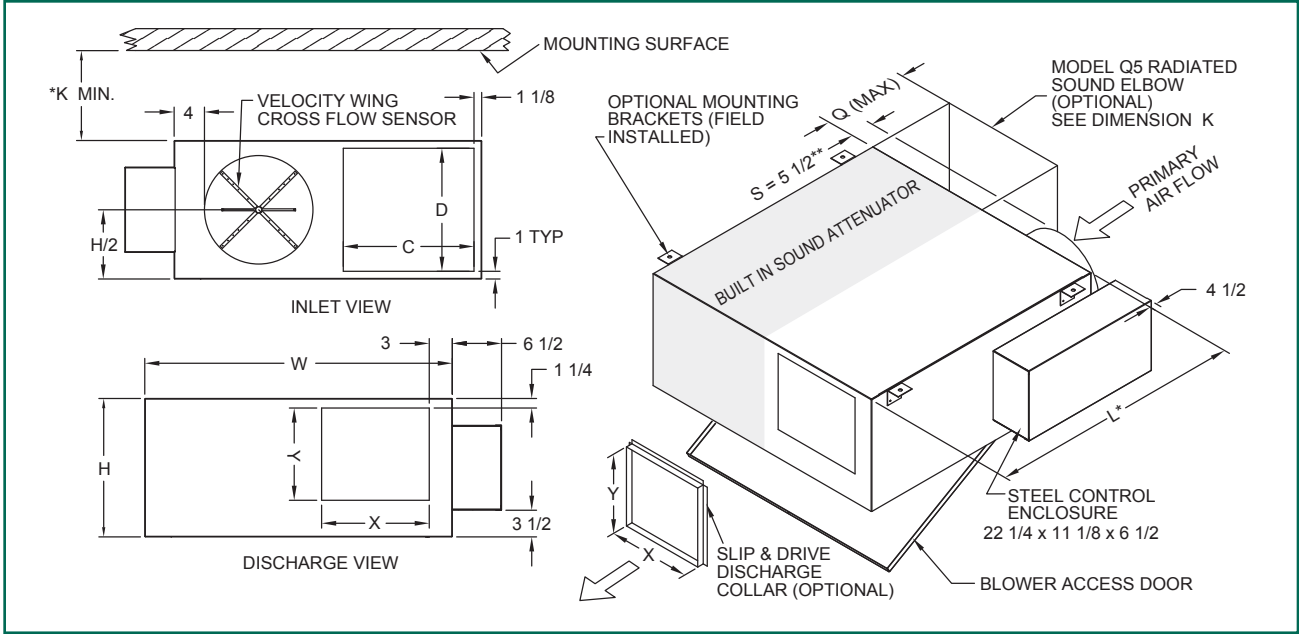

Model Number QSTS	Motor H.P.	Nominal Inlet Diameter	Height H	Width W	Length L	Min. K	Discharge		Induction		Q	Est. Wt. LB
							X	Y	C	D		
1706, 1707, 1708	1/6	6, 7, 8	18	32	36	6	11 1/2	11	12	16	18	117
2508, 2509, 2510	1/4	8, 9, 10	18	32	36	6	11 1/2	11	12	16	18	124
5010, 5012, 5014	1/2	10, 12, 14	18	40	40	6	14	12	17	16	18	139
7512, 7514	3/4	12, 14	20	48	48	8	19	16	21	18	20	187
1012, 1014, 1016	1	12, 14, 16	20	48	48	8	19	16	21	18	20	191