

**APPLICATION**

- Harsh environments dictating stainless steel performance
- Recommended for general return or exhaust of room air
- High free area offering lowest sound and pressure levels
- "Egg Crate" construction similar in appearance to many lighting fixtures
- Surface mounted or suspended grid systems

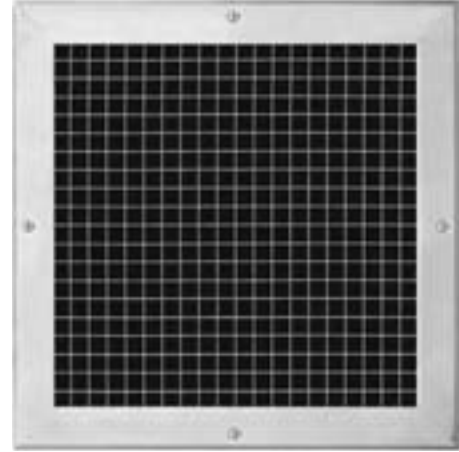

**PRODUCT FEATURES**

- 304 Stainless Steel construction
- 1/2" x 1/2" x 1/2" stainless steel grid core
- 20 gauge frame
- Registers include a factory attached, face-operated stainless steel opposed blade volume control damper
- Mounting holes in frame neatly countersunk for supplied stainless steel oval head screws
- Satin polished frame. Core is 2B mill finish.
- Maximum size one piece construction is 48" x 48". Larger sizes available.

**GRILLE OPTIONS**

- 316 Stainless Steel
- White baked-on paint
- Custom or optional paint colors

**PERFORMANCE DATA - Page B-14**

**SURFACE MOUNTED**

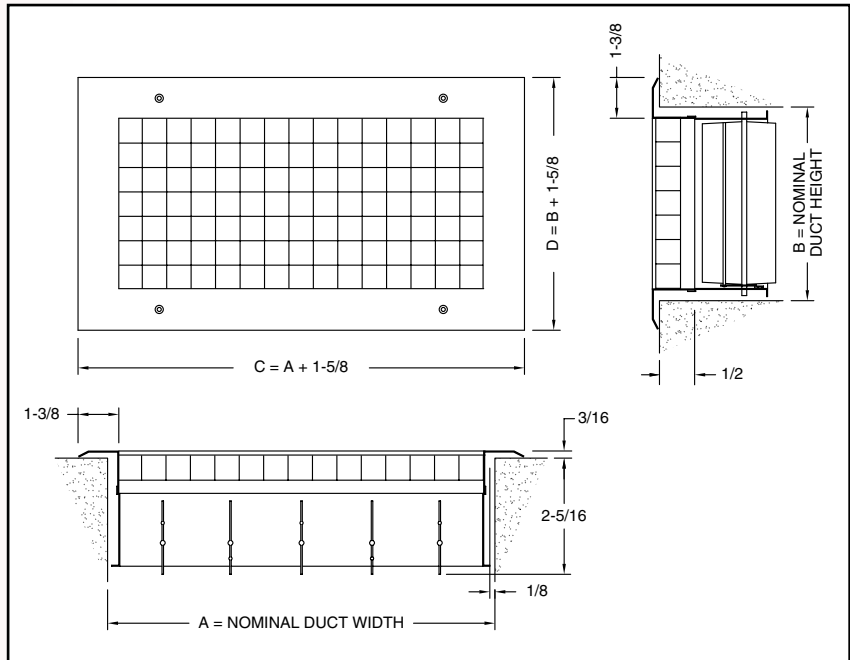

**LAY-IN T-BAR**

