

APPLICATION

- Recommended for constant and variable air volume heating, cooling, and ventilating
- Sidewall, sill, or cabinet installation – blanketing large surface areas with conditioned air (not recommended for foot traffic)
- Required adjustment flexibility - 4 discharge directions plus spread control

PRODUCT FEATURES

- “Rotatable” core can be field adjusted 4 different ways - 5° or 15°, up or down, providing air directional control for the specific application
- Blades on 1/4" centers, vertical support bars are on 5" centers
- Second set of blades double the deflection and provide spread control
- Durable extruded aluminum construction
- Concealed fastening thru neck of grille – No exposed screws
- Registers include a factory attached, steel opposed blade volume control damper
- Arctic White baked-on finish
- Maximum size is 48" x 48" in one piece construction. Sizes over 48" are shipped in multiple sections for field assembly.

GRILLE OPTIONS

- Model RC removable core frame (visible mounting screws thru XR2 border)
- Silhouette finish – satin anodize frame and black core with satin anodize front edges, providing unique color contrast and high end appearance
- Custom or optional paint colors
- Factory applied gasket material to frame
- Aluminum opposed blade volume control dampers

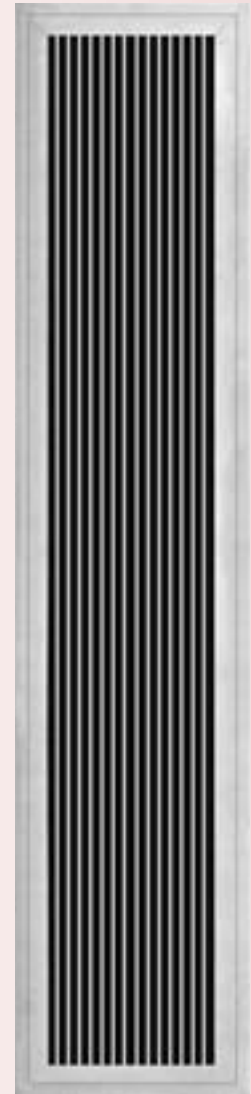
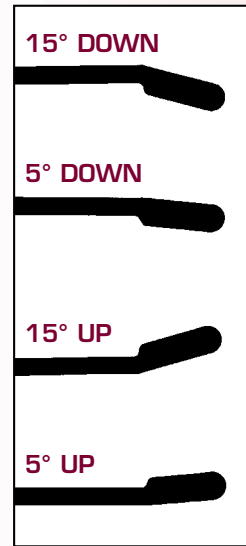
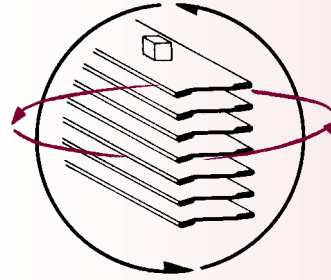

Silhouette Finish

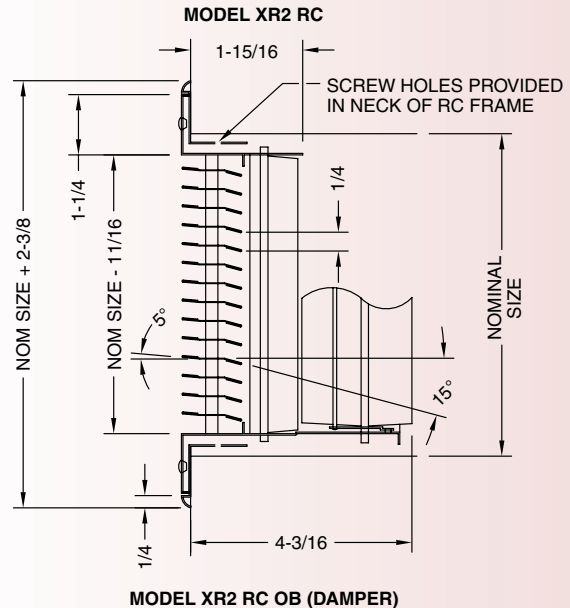
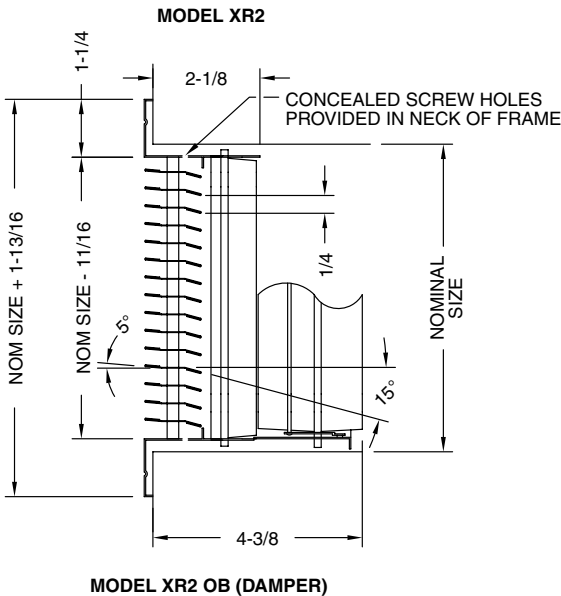

APPLICATION

- Matching return air grille / registers for supply models XR2 & XR2 RC
- Sidewall or floor - surface installation (not designed for foot traffic)
- Can be used as single deflection supply air grille / register

PRODUCT FEATURES

- Blades on 1/4" centers, vertical support bars are on 5" centers
- Durable extruded aluminum construction
- Concealed fastening thru neck of grille – No exposed screws
- Registers include a factory attached, steel opposed blade volume control damper
- Arctic White baked-on finish
- Maximum size is 48" x 48" in one piece construction. Sizes over 48" are shipped in multiple sections for field assembly

GRILLE OPTIONS

- Model RC removable core frame (visible mounting screws thru XR3 border)
- Silhouette finish – satin anodize frame and black core with satin anodize front edges, providing unique color contrast and high end appearance
- Custom or optional paint colors
- Factory applied gasket material to frame
- Aluminum opposed blade volume control dampers

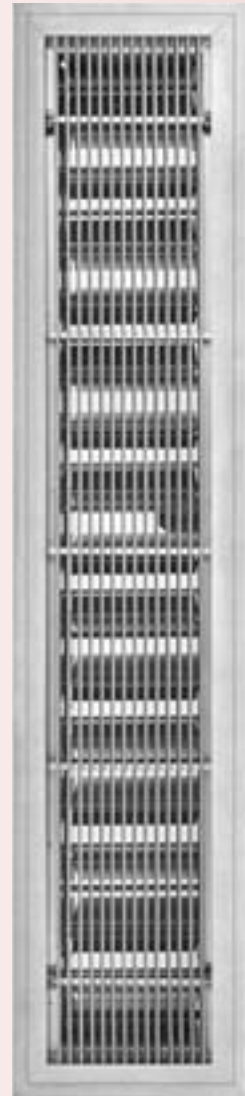
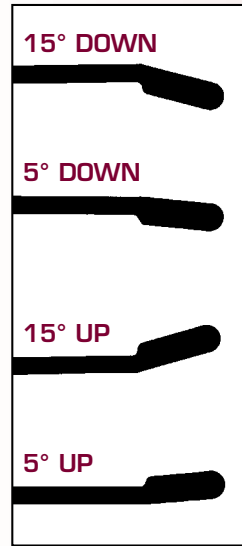
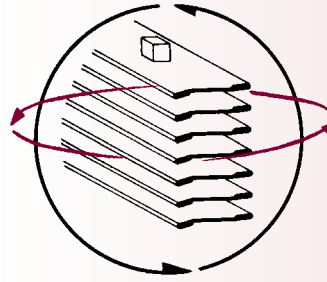

Aluminum Bar Grilles & Registers

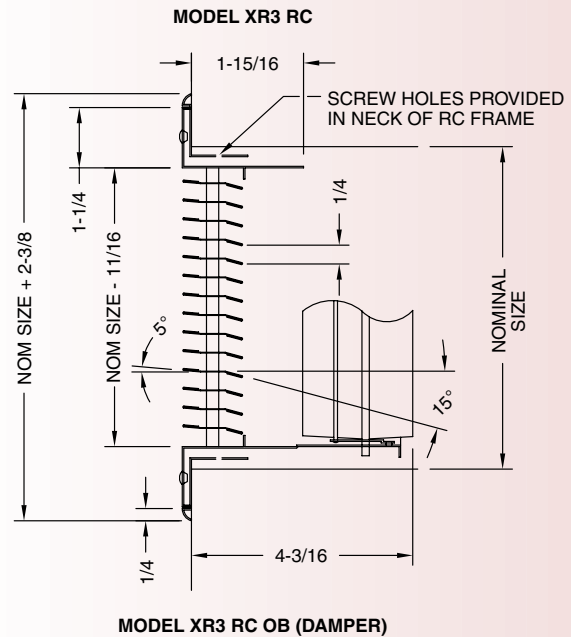
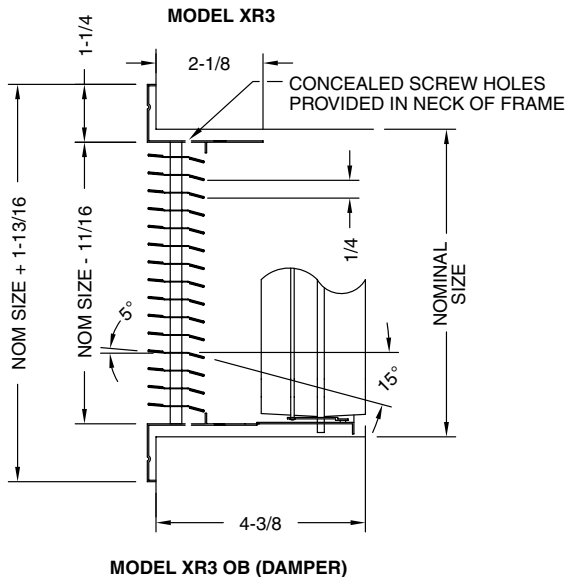

APPLICATION

- Filtered return air grille with filter located behind hinged Rotacore assembly
- Sidewall or floor - surface installation (not designed for foot traffic)
- Room-side replaceable filter frame design

PRODUCT FEATURES

- Hinged Rotacore assembly using continuous, piano style hinge (hinge on long dimension)
- Core is fixed at 15° deflection towards hinge side
- 1/4 turn fasteners for easy filter removal and replacement
- Model XR3-81 accepts 1" filter (by others). Model XR3-82 accepts 2" filter (by others)
- Core assembly blades on 1/4" centers, vertical support bars are on 5" centers
- Durable extruded aluminum construction
- Concealed fastening thru neck of grille – No exposed screws
- Arctic White baked-on finish
- Maximum size is 48" x 48"

GRILLE OPTIONS

- 1" or 2" inch filters factory furnished. Available as "throw away" or cleanable aluminum or stainless steel mesh.
- Silhouette finish – satin anodize frame and black core with satin anodize front edges, providing unique color contrast and high end appearance
- Custom or optional paint colors
- Factory applied gasket material to frame

PERFORMANCE

- Add the filter pressure drop to the grille pressure drop to determine static pressure requirement

